

www.kotobarabia.com

الاقتصاد الإسلامي

بين البحث والنظرية والتطبيق



www.kotobarabia.com

د. زينب صالح الأشوح

:

الاقتصاد الإسلامي

بين البحث والنظرية والتطبيق

تأليف

/

-

طبقا لقوانين الملكية الفكرية

جميع حقوق النشر و التوزيع الالكتروني
لهذا المصنف محفوظة لكتب عربية. يحظر
نقل أو إعادة نسخ أو إعادة بيع أى جزء من
هذا المصنف و بثه الكترونيا (عبر الانترنت أو
للمكتبات الالكترونية أو الأقراص المدمجة أو أى
وسيلة أخرى) دون الحصول على إذن كتابي من
كتب عربية. حقوق الطبع الورقى محفوظة
للمؤلف أو ناشره طبقا للتعاقدات السارية.

— —

:

.

الباب الأول

تعريف الاقتصاد الإسلامي وخصائصه وكيفية البحث فيه ١٨

..... :
..... :
..... :
..... :

الباب الثاني

النظرية الاقتصادية في الإسلام ٢٢٠

: :
..... :
..... :
..... :
..... :

الباب الثالث

بعض النماذج على دراسات تطبيقية في مجال الاقتصاد

الإسلامي ٦١٧

..... 0 :

..... 0 :

/ :

..... 0 :

..... :

”

”

”

”

—

()

—

”

”

.

.

-

.

)

.(

:

.

()

":

)"

.(

:

:

.

۱۳۸۵

)

.(-

-

-

-

-

()

.

.

"

"

.

☾ :

.(:)☾

" "

.()

☾ :

.(:) ☾

"

—



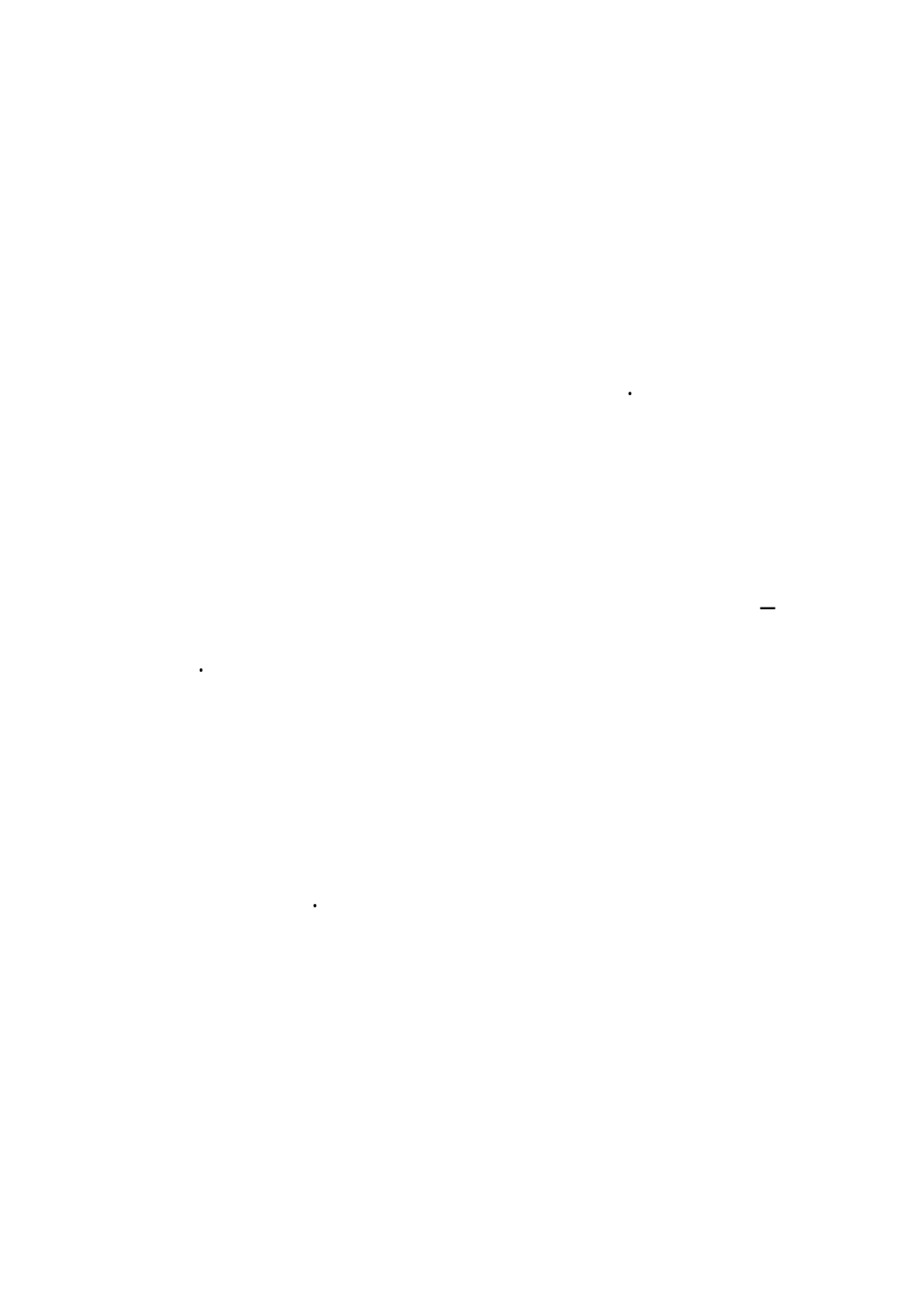

)

(

الباب الأول

**تعريف الاقتصاد الإسلامي وخصائصه
وكيفية البحث فيه**

☾ :

*

*

*

(- :) ☾

☾ :

*

- :) (

(

)

(

()

) :

*

.(- :) (

-

-

.

.

..

.

الفصل الأول

ما هو الاقتصاد الإسلامي؟

-

()

.

)

.(...

:

- -

"

"

.

"

"

"

"

(

)

-

"

"

()

()

()

()

.

()

()

"

"

.

.

-

-

"

"

-

)

.(

)."

"

.(

(:)

()

(

()

()

(

()

()

()

()

()

.

.

.

-

-

)

()

()

.

.

:"

"

- -

!

-

-

()

" "

.

...

.

— —

— —

— —

— —

— —

) (

) (

) (

" " (

" "

() .

☺ :

*

(-) ☺

)

.(-

" "

() ()

- -

.

“ ”

“ .
.”

“ ”

—

—

.

“ ” “ ” “ ” “ ”

“

”

.

“ ”
.”

”

— —

“ ” “ ” “ ” “ ”

.

.

-

-

-

)

"

-

-

)

(

)

-

:

()

.(

-

" "

)

(:

()

.

..

-

-

-

-

-

"

"

-

"

"

.

-

-

()

الفصل الثاني
بعض خصائص الاقتصاد الإسلامي
والدلائل النظرية على فعاليته

()

.

١-٢-١ ، خصائص تتعلق بالدراسة والبحث:

:

:

:

.

..

.

—

—

—

—

.

.

—

—

.

()

- -

.

☾ :

:) ☾

☾ :

() ☾

☾

☾ :

.()

-

-

-

..

..

.

" : ﷺ

) "

.(

— —
— —

.

.

" ;
:

"

)

.(-

:

:

.

-

) (

-

-

):

.(:

-

-

()

*

):

.(:) (

)

" : 聖 : .(
)"

.

.(

.

)

(

) (

) :

(

" :

.() ."

()

家

.

":

)"

.(-

- -

⌋:

.()⌋

:

:

)

(

.

.

"

"

.

:

"

:

السلامة
والصحة

:

)"

.(

-

.

—

)

(

.

☞ :

:(:) ☞

" : ۱۱۱۱

:)"

.(-

: - -

-

-

.

:

:

.

.

• $\frac{1}{2} \times \frac{1}{2} = \frac{1}{4}$

••

•

•
•

•
•

•
•

)

.

.(

.

.

-

.

()

:

" :

"

"

)"

.(

)

(..

)

(

.(

)

-

"

" :

.

:

"

"

.

.

)

)

(

)

(

(

)

(

-

.

)

(

-

-

-

)

)

.(

.

()

()

()

.

()

:

-

()

.

-

-

.

-

-

)

-

-

.(

.

:

-

":

)"

-

:

(

-

-

" : ۱۱۱۱۱۱۱۱

) "

.(

..

-

.

)

.

(

.

)

(

.

)
) (
) (

.(

-

"^{٢٠١٤} :
٢٠١٤

:)"

.(() / : / /

() :

) ()

.(

..

.

()
.()

)

(

()

"

" : 1988

/ :)

.(: /

() ()

:)

.(-

:

:

()

()

-

.

.

.

-

-

-

-

-

.

.

.(

⌋ :

) ⌋

-

.

.

:

--

-

.

:

.

:

()

()

⦿ :

.() ⦿

...

⦿ :

⦿

.()

)

)

(

(

)

(

.

.

.

()

. ()

.()

()

.

" : *all
state
2008*

:

)"

.(-

.

.

:

:

" :

المعنى

) "

.(-

" :

) "

.(-

)

(

.

.

()

:

":

)"

:

.(

":

...

)"

.(

-

...

() -

" :

:

) "

(

(

.

" :

...

-
)"

-

.(-

..

!

:

:

-

.

-

.

(

)

()

.

.

.

:

" : ۱۳۸۳

)"

.(

.

۱۳۸۳ :

(:) ۱۳۸۳

:(

) ۱۳۸۳

)"

"

.(

.

.

:

"

"

-

-

.

:

" :

)"

(

.

☞:

() ☞

☞:

. () ☞

☞:

. (:) ☞

☞:

() ☞

.

) ()

":

(

)"

(

.

.

" :

" :

:

)"

:

(-

" : () 

)"

.(

:

" :

:

)"

(

)"

:

:

.(

()

" :

⊗

"

:

:

)

.(

: ۱۱۱۱

"

)!"

.(

:

-

!

..

.

.

.

.

:

:

-

-

()

.

.

-

(

)

-

.

..

.

- -

()

.

.

.

()

:

☾ :

.()☾

.

.()

" :

:

:

)"

.(

☞ :

.(:)☞

:

" " 此

.

" : 此

) "

" "

.(

:

(

此

“ ”

—

.()

*

*

∴

*

.(- :)

*

()

)

.(

":

)"

(-

:

⌈

:

:

"

)"

.(-

" : 

:

:

:

)"

.(-

)"

":

.(

:

()

()
)

-(

)

):

(

.

":

"

.(())

" :

) "

.(:

" : 

)"

:

-

(

" : ﷺ .

.

)"

.(-

:

(

.

"

"

(

)

- -

☾ :

.(:) ☾

.

.

-

.

☾ :

.(:) ☾

" :

) "

:

.(

" :

書

)"

.(

()

.()

)

(

()

-

.

) " : ()

. (-

":
) "
(-

":
) "
. (-

-

":

) "

.(

..

.

:

(

.

-

“ ”

()

: () ”

-
-
:
) .(
() / () /

.

- -

.

-

. . .

()

" : () 𐤀𐤁𐤃𐤄

) "

.(

-

) "

" : 𐤀𐤁𐤃𐤄

.(

" 𐤀𐤁𐤃𐤄

)"

.(

":

)"

.(-

.

-

-

":

)"

(-

:

":

)"

.(-

()

.

-

" : ..

-) " .(

عَلَيْهِ
" : " :

"

(- /))
(/ - (/)
. (/)



.(:)

.

.

" :

) "

-

.(

.

()

(

.()

.

.

: (

-

" "

☺ :

.() ☺

" : 此

.(/)"

" : 此

)"
(
)"

":

(

☺:

() ☺

☺:

" "

.(:) ☺

" "

.

:

-

-

-

()

" :

)"

.(

"

)"

.(

":

此

)"

.

.(

.

.

":

此

)"

.(

ﷺ

)"

":

.(

()

:

-

)

(

)

.(

)

)

(

)

(

) (" "

.(

.

..

.



.(:)

.

:)

*

:)

.(

.

.

-

-

-

الفصل الثالث
كيفية البحث في مجال الاقتصاد
الإسلامي

.

-

-

.



١-٣-١ الركانز والخطوات العامة للبحث العلمي ومدى صلاحيتها
للتطبيق على الاقتصاد الإسلامي:



()

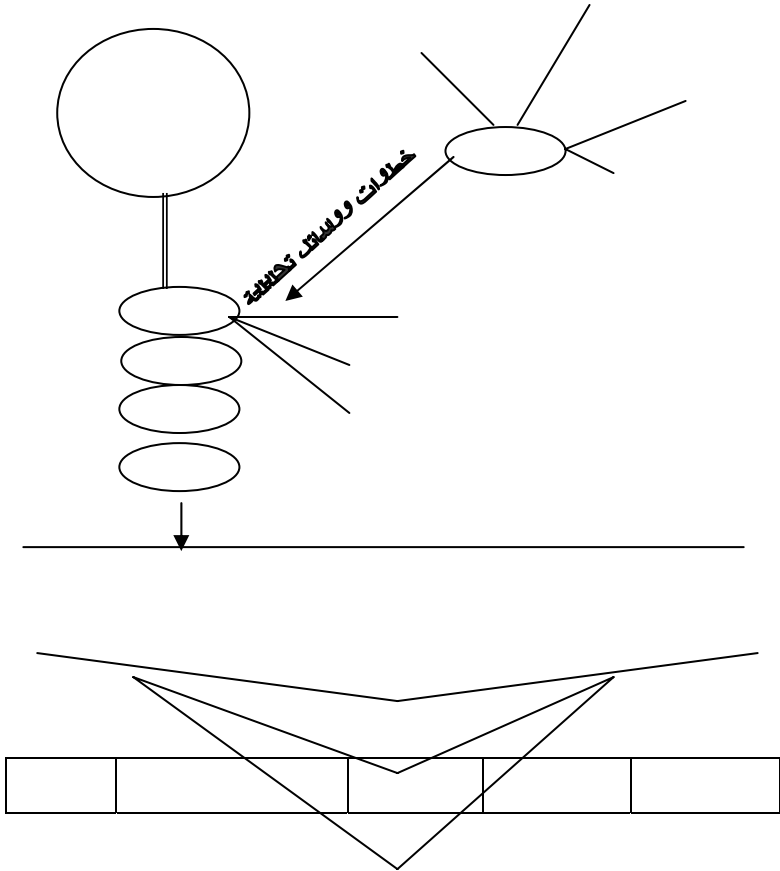

()

-

.

..

..

.

..

.

:

:

.

:

:

()

-

..

.

:

()

)

) (.(: ()

: . ()

. : ()

.

:

()

.

.

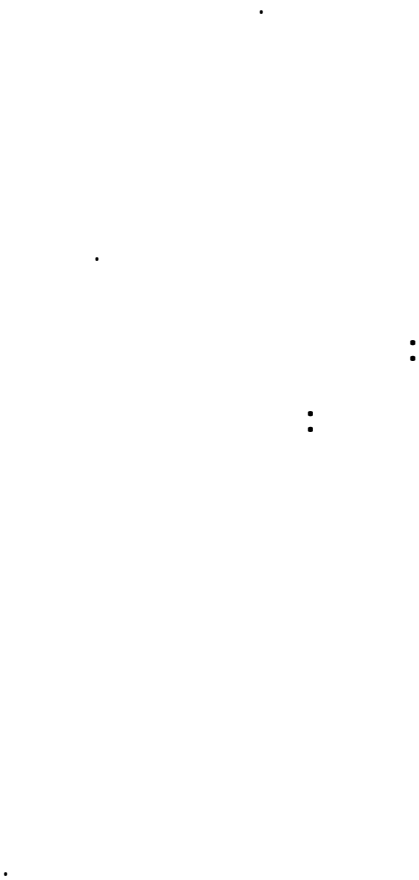

:

()

☾ :

☾

*

:

(- :)

() (

)

(

" : ()

) "

.(-

(

:

(

.

(

-

.

:

()

:

:

(

.

()

.

.

)

(

: ()

·
:

)

(

· ..

·

..

.

.

-

-

.

)

.(

-

.

.

)

(

)

.(..

:

(

.

.

.

.

)

.

.

.

.

:

. .. - (- ()

.

.

.

.

- -

.

()

.





.

:

.

.

()

-

-

-

.

.

.(

)

.

.



.(:)

Uncertainty

..

.

:

:

()

()

" " " " :

" " " " " "

" " "

.

.

۱۱۱۱

()

" :

۱۱۱۱

"

:

(

)

۱۱۱۱

)"

":

.(

) ﴿

:

.(

."

"

"

/ .) :
.(

.
--
:

.

)

:

:(

:

()

-

()

()

)"

☞

.(

/

☞

:

☞

(:) ☞

☞ :

*

.(:) ☞

.

☾ :

.(:) .☾

—

.

.

• 3/5

☾ :

☾ : (:) ☾

☾

☾ : (:)

(:) ☾

☾ :

☾ : (:) ☾

:) ☾

.(

!!

!

.. " : ۱۱۱۱

) "

.(

" : ۱۱۱۱

:

) "

.(

”：

“() ”

”：

“() ”

·

” ”

·

：

—

：

·
" " " "

·

) .

-)

.(

()

()

"

"

)

:

.(

-

/

第
三
章

:

"

"

)"

" : ۱۳۸۵

.(

) (

()

۱۳۸۵

()

:

.

()

.

()

.(/)

-

-



"

"

.

()

)

/

:

:

:

.("

:

" : 流

) "

.(-

()

.

)

(

)

(/

.

-

...

流

-

-

...

.

" : " ...

" : ...

...

" ...

:

...

...

" ...

"

...

" ..

" :

/

)

)

)

.(

()

:

.

.

()
) ()

.(

3333

)

:

(

3333

∩ :

∩

*

*

.(- :)

) "

" ∩ ∩ ∩ ∩

.(

...

..

" "

" .

.

...

...

...

...

()

.

.

.

()

⋮

⋮

⋮ ()

⋮

) .

.(- -

.

()

.

(

(

.

.

)

:

:(

:

()

.

.

)

/

.(

(

(

/

)

)

⋮

:

:

)

*

)

/

.(

)

(-

/

-

-

.

:)

.(

:(
.(/)

() /

()

.

.

- /) /

(

 :()

 : -

 (-) -

 .

) -

 .(

 : -

 -

 .()

) -

 .(

 : -

 /) -

 .(

 -

 .()

) : -
-
.
(
-
.() .
:
-
-
.()
-
:
()

-

.

()

()

.

.

:

()

-

!

" "

." "

.

)

.(

.

- -

/ / /)

(/) (

.

:

()

..

-

-

.

.

:

()

(-

/ :)

:

()

.

.

()

..

“ ”

.

“

”

()

:

.

“

”

.

/

()

)

(

.

-

.

-

-

()

.

.

.

()

.

..

:

()

"

"

.

.

.

.

.

.

Les "

"

Physiocrates

"

"

.

Economists

)

(

.(-

)

.

.

..

)

(

(

)

.

)
)

(

.(

:

- -

-

:

:

:

)

()

(

)

) ()
. (

(&) ()

()

.

(et)

()

.

() ()

.

()

))

.. :

.(

()

.

:

:

:

()

()

.

()

:

/ ()

. ()

()

()

.

()

:

/

"

() "

.

()

()

-:

/

() " "

()

.

()

:

/

" () Volume

() Series ()

() Number ()

()

:

)

(

)

/

(

)

()

.(

(

()

()

. ()
()

.
.()

.
:
:
()

·
:

·
()

·
()

·
()

.
)
(
.
) ()
(
-) Periodicals Books
-) (Islamic
.Theses (

:

:

.

:

۱۳۸۵

)

(

"

۱۳۸۵

"

)

.(

"

" :

()

" :

"
.

.

.. " :

.() " ..

" : () 2016

.) (-) "

) "

" : 

:

:

.) (

:

.

.()

()

-

-

-

.

:

)"

"

(

/

"

":

.(

)

.

:

.

..
()
)
(
) ..
(
()

" : 卷

.

)"

" : ۱۳۸۵

(

"

)

.(

"

"

.

..

.

-

.()

:

"

"

-

.

!

* * *

الباب الثاني

النظرية الاقتصادية في الإسلام

"

.

"

.

.

.

)

.

(

الفصل الأول

**تعريف النظرية الاقتصادية الإسلامية
وبعض متعلقاتها:**

— —

.

.

- -

.

:

- -

()

"

Theory " "

"

"

"

"

:

.

"

)"

"

(

)"

.(

(

)

.

)

(

.

:

)

(

.

.

" :

”

()

: Low

.
- -
:
:

Hypothesis

.

:

Assumptions

Observations :

Standard :

(Principle :)

" Indicator :

:Axiom :

" :

."

-

-

.

/

.

))

)

(

()

(

-

-

.

.

()

()

()

.

"
:

.

.

"

.

..

()

.

() /

.

-

-

.()

-

.

.

—

-

()

-

/

(/)

"

()

)

(

()

()

.

"

"

.

)

(

()" "

-

. ()

الفصل الثاني
بعض الأفكار الاقتصادية الإسلامية
قبل ظهور الرسالة الحمديّة

—

—

.

.

!!!

..

" :

"
.

.

:

2008

.

- -

•

☺ :



:

.(:)

" : 𐌆𐌇𐌈

:

)"

(

: 𐌆𐌇𐌈

"

)"

:

:

.(

) 𐌆𐌇𐌈



(:

.

.

) 卷

" :(

) "

.(

.

卷

:

-

" : 卷

()) . () "

.(/

) :

) (

.(:

-

-

.

:

) (

)

.(

" "

:Usury

" "

" " " "

.

" "

.

()

()

.

" "

.

()

.

.

.

()

!

-:

" ()

.(:)" "

" ()

: ..)"

.(

" ()

:

.(:)"

.

" : " "

!"

.

-

-

" "

.

-

-

)

:

.(

()
()
()

() ()
()

.. ..

!!

:

:

Sustainable Development

:

)

(

()

.

) :

()

:

" :

:

) " ..

(

) :

.(:)

—

.

.

☾ :

*

.()☾

-

-

)
(

()

()

☾ :

.() ☾

:

:

()

!!

-

-

()

☾ :

() ☾

☾ :

☾

()

—

—

☾ :

. (:) ☾

) (

) :

(

.

) :

.(

) (

.

.

" :

)"

.(

—

—

(:)

)

()

"

"

:

: ()

.

: ()

.

: ()

.

()

• 2023

- -

•

-

-

☾ :

•

*

*

(-) ☾
)

(

()

()

)

.(

.

" :

) "

.(

• $\frac{1}{2}$

—

•

⋮

⋮

—

—

.

-)

-

.(

-

-

۱۳۹۸

.

.

()

: 卷

:

"

)"

:

.(-

" : 卷

)"

.(

" : 𐎠𐎡𐎢𐎣

)"

.(

.

()

:

)

(..

.

:

:

.

)

(

.

-

-

-

-

.

.

) (

) :

☾:

(

.() ☾

)

:

(

:

∴ .

∴ ∴

∴ ∴

∴ .

()

∴

.

∴

∴

) ...

.(

" "

()

.

.

)"

..

:

:

.(

:

() () :



(:) ()

:

*

.(- :) ()

-

-

.

:

() () ()

.

)

(..

)

.(

))
) (.(
.

(:)



.

:

:

.

.

()

-

.

-

-

-

-

-

()

()

-

!(

. ..

:

:

!

-

-

-

:

:

:

:

☾ :

☾

()

..

.

()

.

.

()

.".

"

" .

" : ۳۳۳

)

.(

:

:

()

:
۳۳۳

*

۳۳۳

.()

)

:

.(^{الله}

.

.(

)



.()

.

: :



.

-

-

.

)

(

.

%

-

..

.

:

-

-

.

.

)

(

). .

(

.()

.) "
.(-

•
•
•



.



.()

•
•
•

.

"

)"

.

(



.()

:

"

"

:

:

:

:

.



:

*

(

:

)



.

:



.(:)

-

-

-

☾ :



.(:)

(/)

-

-

(/)

-

-

"

"

.

:

.

—

—

.

.

—



:

.

. ()

:

. (:)

:

(:)

:

*

*

*

*

*

*

.(-)

)

:

-

(-

..
":
()"
":
):
):
:(-

⋮

•

—

•

*

*

.(- :)

:
)

)

.()

-

-

()

“ ”

-

-

.

..

-

.

.

.

☾ :

*

(☾) ☾

..

.

:

:

.

—

"

"

.

.

.



(:)

:

*

*

.(-)

:

*

*

*

*

:

(-)

(:)

:



*

:)

.(

) :

.(:)



()

) :

(

) (

) :

(

" : 齋

.(")" ..

-

.

-

" : ﷺ

:

()

."

☾ :

(:) ☾

☾ :

.(:)

.

:

-

-

:

.

.()

)

)

)

.()

": 壽

)"

(

☺ :

(

) ☺

:

☞ :

.(:)☞

—

.

.

:

)

(

-

.

(

)

☾:

.() ☾

)

:

(.

.

-



*

.() ☾

.() :

.

⌋ :

.() ⌋

:

) ⌋

*

⌋

.(

.

.

*

☾ :

*

) ☾

.(-

.()

☾ :

.(:) ☾

☾ :

.(:)☾

.

.

☾ :

*

*

*

(-)

.



()

:
)

()

:
)

)

.(

.

/

(/)

.

☾

☾

(:)

☾ :

(:) ☾

(:)

!

)

*

.(

."

"

☾

☾

.()

-

() () :

) :

 () ()

.

/

()

-



*

)

()

. (

()

.(:)

!

-

.

.

☾ :

.(:) ☾

☾ :



. *

.()

)

(

"

"

()

()

" :

/)"
/ /
.(:
:

(-)
" :
: :
:
:

) "...

:

.(-

":

:

.()"

..

()

-

☺ :

.(

)☺

.

..

-

الفصل الثالث
بعد الأفكار والتطبيقات الاقتصادية
الإسلامية
بعد ظهور الرسالة الحمديّة

—

—

—

“

”

()

.

.

.

- -

:

.

()

此
處

()

) ()

.)

- ۱۳۸۸

-

.

۱۳۸۸

.

" : ۱۱۱۱۱۱

! :

)"

.(-

- ۱۱۱۱۱۱

-

()

" : ۱۱۱۱۱۱

.

-

-

"()

: () ()
. (

)
(

) .
. (

.

.

.

.

.

.

.

.

.

.

.

.

⋮

⋮

⋮

⋮

⋮

.

.

()

)

.(

.

-

-

)

.(

" :

.(

)"

⋮

" ⋮

)"

.(

"

)"

(-

!

":

)"

此

(-

"

)"

-

.(

.

" : 此

"

)

.(/

.

()

/

)

(

.

—

—

.

.

" .
.

"

.(/ " :) "

-

" :
()
"
() ()
.(

" :

" .

—

—

.

" :

"

" :

." ()

..

.

()
() ."

" :
()

()

:
.(

-

-

-

-

!

-

.

.

()

)
" :(

()) ."

()

: ()

.(

()

-

-

-

.(:) (

) :

-

.

-

"

"

"

"

()

"

.(()) "

-

-

()

-

()

.

:

-

()

" :

"

)

.(

.

"

"

" :

"

.

)

(

-

.

.

()

)

-(

.

.(-) .

·
:
:

()

.

.

"

"

"

"

—

.

.

" "

-

-

-

.

)
(

⌋ :

) ⌋

(

.

.

.)

.(

-

-

...

(

)

!

()

.()

-

.

:

:

"

"

-

-

.

.

.

.

()

-

.

-

.

.

(

)

)

(

.

.

()

:

.

..

.

.

)

(...

.

: (-)

.

:

:

()

-

-

.

()

-

-

() ()
.() ()
:
: (- / -)

(النقود والتجارة)

-) / .(

·
"

"

()

· ()

·

:

()

!()

·

·

()

:

()

-

)

.(

-

)

.(..

:

-

-

.

-

)

.(

)

:

-

(

:

.(

)

-

!

.

-

-

.

:

()

.

()

-

.

-

.

.

.

.

()

()

:

..

-

-

-

-

()
.()

-

.

" .
.

"

" .
.

"

.
.

.

"

"

.

:

()

.

.

!

-

-

.

)

(

.

.

:

()

-

-

-

.

:

"

.

)

(

:

)

(

"
۱۳۸۶

- "

"

" :

-

.

) .

:

.(

:

()

..

-

)

(

-

-

-

-

: ()

-

.

..

.

-

-

-

:

()

.

()

)

.(

()

.

:

()

.

()

:

.

-

:

):

()

.(

.

: ()

.
: ()

- -
-

!
: ()

-

—
.
: () ()
()

— —

.
:
()

—

—

:

()

" :

" :

.. "

"

:

()

-

.

-

.

”

”

： ()

—

—

) (-
-

)

.(

-)

:

:() (- /

" "

.

.

/

.

)

(

.

-

-

." "

)

(

·
: ()
" ()

·

·

·

·

-

·

:

-

.

) :

)

) :

(

(

)

:

()

.

.

-

" ,
.

"

.

"

"

•

•

•

-

"

•

•

家

•

•

•

•

•

•

•

•

•

•

•

•

•

•

() ()

.... ...

.

()

-

.

:

-

.()

()

-

)

-

(

"

":

"

-

"

"

-

-

.

!

-

..

.

:

.

-

.

" .

.

"

.

.

.

)

(

.

.

" :

."

)"

"

:

:

.(

.

)

(

.

- -

.

:

(

:

.

()

"

"

"

"

"

"

"

.(() "

-

"

"

-

.

"

"

.

.

:

.

.

"

.

"

"

":

"

)"

.(



.

.() ()

.

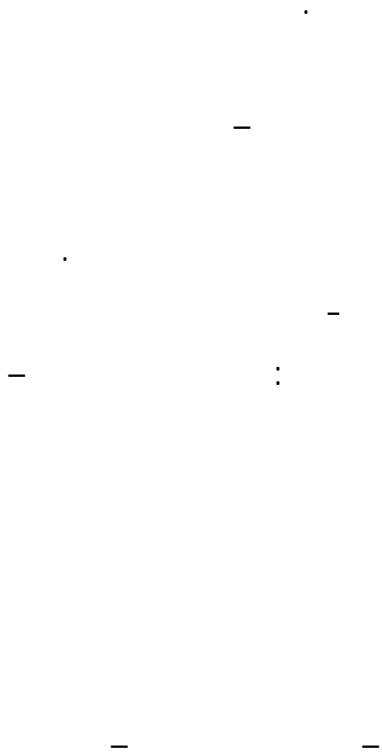

第

()

()

.(()) .

..

:

:

"

"

:

:

"

:

)

.()

" : 3

)"

.(

:

()

-

-

.

) :

.(:)

.

()

.

()

()

.

) ()

. ... (

) ()

(

.

.

)

(

.

.
:
()

.
()

-

-

.

()

. ..

)

. (

.

":

"

.

☾ :

.(:) ☾

*

-

.

-

-

:

!

()

.()

!

()

()

.()

.

()

!!!

!

:

۱۱۱۱

۱۱۱۱

" :

) ."

.(

..

..

/)

:

:() (/

()

)

.

(

"

"

..

"

"

"

"

.

—

.

"

"

"

"

"

"

-

-

.

.

()

:

" .
.

"
.

-

-

-

-

()
-

-

☾ :

.(:)☾

—

!

.

()

:

-

.

.

.

:

.

"

:

()

."

)

.(

.

" : ۱۱۱۱۱۱

()

() "

(/

" : ۱۱۱۱۱۱

) "

...

:(
/

- -

):

(

":

.

."

()

.()

.

" :

)"

.(

.

.

:

()

:

.

"

"

.

: ... ()

.

.

.

()

.

" :

"
.

" :

"
.

:

()

.

—

.

.

" :

"
.

-

.()

..

" :

.

"
.

.

.

()

()

-

..

.

:

()

)

(

":

"
.

()

.

.

" :

) "

/

.(

:

"

"

"

"

.

..

.

)

:

:(

(

-

"

"

.

.

:

()

.

.

-

()

.

:

()

.

:

-

.

-

)

(

:

.

()

.

" :

"

.

:

()

" . . .
 . . .
 . . .

"
 .

()

.

()
 .(

:

.

-) :

:()(

"

"

“

”

.

“

”

“

”

”

”

.

“

”

.

()

()

-

.

)

(

.

.

)

)

(

(

)

.(

" : 樂

:

:

)"

.(

()

:

-

(

)

)

()

)

(

(

)

()

)

(

)

(

:

()

()

.

)

(

.

.

-

-

.

.

":

."

() ()

.

()

) %

.(×
)

(

.

.

-

.

.

)

(

.

-

(-)

()

(-)

)

(

)

.(

-

)

(

.

)

(

.

:

()

:

)

(

()

)

.(

=

:

=

.

=

=

(×)

)

()

(

)

.(

.

"

11

.

.

.

.

()

:

.()" "

.

:

)

-

:(

.

:

)

-

.(

)

-

.(

.

)

-

(

.

)

(

()

:

)

(

-

:

-

.

()

:

-

()

.

.

.

)

(

.

) - - .
- -
) .
.(

.
-
()
()
()

—

.

.

.

"

"

)

"

."

(

)!

.(-

...

”

”

·

”

”

”

”

()

·

" . "

" "

" "

" "

" "

!

.

!

- -

:

مقدمة:

﴿

.(

)﴾

%

() ()

☾ :

.() ☾

☾

()

()

.

.

:

:

...

!..

•

•

||

"

☾ :

.(:) ☽

()

.

()

.

☽

) ☽

.(

)

(

- -

.

..

..

.

()
)

(- -

.

)

(

.

:

:

: ()



.(:) ☾

.

.(/) " : ☾

.....) : : : ()
.() ()

.

)

(

:

.

..

" :
: 2011

:

) "

.(

: ()

☾ : :

:(:) ☾

.

.

.

☾ :

.

☾

. () ()
: ()
) () :
() . (

.
:

"
)"
. (: ()
) :

.(: ☾

:

☾ :

:

☾

)

(

.

:

()

:

☾

*

:(:) ☾

()

.

()

.

: ()

:



(:)



()

.

..

..

..

..

.

()

) ..)

.(

.()

: ()

:()



.(:)

:

.

... " : ۱۱۱۱

.

) "

.(

-

)

:

*

.(

"

"

)

.(

: ()

:

↗

.()

() ()

)

-

(

)

.(

(

)

(

)

..

(

)

.

..

)
(

.

. ..

)
(

..

.

..

: ()

☞ :

.(:) ☞

.

()

()

-

-

()

()

..

.

: ()

:



.(:)

..

).

.(

()

.()

()

:



*

.(



.

.

()

.

.

)

.(

:

:

()

:

!)

*

*

)

.(- :

.

()

-

":



:

)

":

.(

)"

:

.(

:

: ()

*

⌋

.(

:

)⌋

⌋

/

)

.(

-

..

!

: ()

:



*

.(- :)

-

-

-

.

: ()

:



.(:)

.

.

: ()

:



.(:)

..

—

—

. ..

: : ()



.(:)

..

-

.

.

: ()

: ()



*

.(:)

.

:

" :

"

.

" :

.

)"

.(

.

.

:

:

:

:

()

.

.

:

:

())

)

)

))

(



(:)

:



.(:)



(:)



:)

.(





(:)

:
:

(:)

:
:

(:)

:
:

.()

:
:



()

. (:) :

..

:



.

. (:)

:

. (:)

:

☾ :

☾

☾ ()

☾ () ☾

) ☾

☾ (

) ☾

.(

☾ :

.() ☾

.()

()

()

.



-

*

.(:)



:

-

)

) (

)

☾ (

:) ☽

.(

-

-

.

:

☽ :

- :

☽ (

) ☽

*

☽ (

:) ☽

☽ (:) ☽

)

.(

-

)

(:)

.

:

()

..

.

.

-

.

☞ :

-

.(:)☞

()

"

-

۱۱۱

.

☾ :

-

☾

..

-

:

☾ :

-

(:) ☾

-

☾ :

☾

☾ (:) ☾

..(:)

-

) ☾

☾ :

.(

)

.(

.

☾ :

-

☾

) (

: (

. (/) (

:

: (

. (/) (

: -

. (:) (

)

:

. ..

.

-

: (

. (

-

-

-

-

)

.(

-

!!

:

-

/

-

☾:

.() ☾

:

-

) ☾

☾

☾ (

.(:) ☾

☾ : -

.(☾) ☾

: -

☾ :

(:) ☾

.

☾ :

) ☾

.(

: -

☾

-

.(:) ☾



*



.(:)

-

-



:

(:)

:



.(:)

.

-

:



*

(:)

) :

(

)

()

()

)

(

" "

)

.(

!

-

.

..

.

.

:

.

()

)

.(

/

.

.

.

:

:

:

)"

"

.(

"

:

":

)

.(

":

"..

)

.(

":

"

)

.(

: " :
()

() "

:

.(-

: " :

) "

.(

.

"

: () "

()

:

:

.

.(

:

"

.()"

.

" :

)"

.(

)"

" :

.(-

" :

) "

:

.(-

" :

) "

.(-

" : /

) "

.(

:

:

":

)"

.(-

.

.()

..()

..

.

:

"

)"

.(-

()) ."

()

"

"

"

"

"

.(

()

()

-

:

":

:

:

:

"

)

.(

...

" :

:

:

"

)"

.(-

" "

" :

()

()

()

()) ."

:

-

.(

.

..

..

..

" :

()

) "

:

.(

-

()

-

.

:

:

:

.

()

-

)

:

()

(

.

..

-

.

.

-

":

:"

)"

.(-

":

-

)"

:

.(-

:

-

":

)"

" (

-

)"

.(

(()) () "

":

.(

"

":

.(

)

":

)"

" (

)"

" (

)"

.(

)"

":

.(

)"

":

:

.(

:

-

:

-

:

"

)"

.(

":

-

"

)

" (

"

.(

)

":

-

)"

.(

":

-

)"

:

.(

" :

-

) "

.(-

" :

-

) "

.(-

" :

-

) "

.(

-

:

...":

:
)" ...
.(-

: -

":

)"

.(

":

)"

.(

":

)"

.(

:

"

" () "

) "

.(

.

":

) "

:

" (

) "

.() (

:

()

.

":

306

"

)

.(

:

.

:

:

()

:

:

.

:

:

:

:

☾ ()

☾

!

()

()

.

.

()

..

Time is Money

.

()

" .
.

:

)"

.(-

.

-

:

()

()

Time

Leisure

:

()

⊗

-

:

":

)"

!

" (

)"

.(

-

:

-

.

"

)"

.(-

()

":

()

() "

.(-

!

)

) (

.(!

.

.

()

:

-

:

:

"

)

.(-

" : 家

.

)"

.(

-

".

:

)"

.(-

-

:

.

.

.

..

.

⌋ :

(⌋) ⌋

*

⌋ :

⌋ .

*

) ﴿

—
: ﴿

—
.
(

: ﴿

”

) ”

(

" : ()

"

) "

:

⌈

(

"

) "

.(

)"

" : ۱۹۸۵

.(

.

" : ۱۹۸۵

)"

.(

()

.

:

.

.

.

:

-

)"

"

)"

(

"

.(

"

)"

.(

:

()

-

)

)

(

..(

.

-

-

.

-

-

.

—

.

.

()

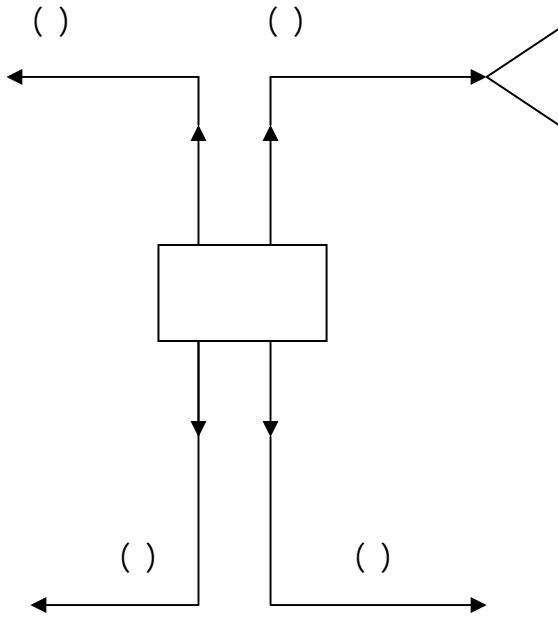

-

-

.

) :

()

()

()

- -

.

()

.

- 2008

-

-

.

:

-

.

☾ :

*

.(:)☾

)

(

)

.(

)

-

.

-

.

.

:

.

-

)

(

.

"

.

)

)"

"

.(

()

-

:

·
" :
.(")"

"
) "
ﷺ

.(

۱۳۸۵

)"

":

.(

.

": ۱۳۸۵

)"

.(-

-

-

۱۳۸۵

"

"

.(

)

" :

) "

.(

۱۳۸۵

"

.(

) "

" : ۱۳۸۵

) "

.(

()

·
" : 家

"

)

.(-

.Leisure

()

)

(

Free ()

Time

)
(

.

.

.

.

.

:

*

)

⌋ :

(

) ⌋

(

-

" :

۱۱۱۱

.

) "

:

.(

.

.

:

"..."

()

" :

)"

.(-

"

)"

.(-

":

)"

!

.

-

.(

:

此

-

-

-

-

此

":

"

:

.

.(

)

:

" : 3000

:

:

.

:

:

:

" () "

) "

(

.(-

:

..

()

.

"

) "

" (

)"

.(

:

"

:

)"

:

" (

)"

" (

>

)"

" (

)"

!

:

:

.(

:

)"

"

" (

.(

)"

:

"

)"

(

)"

" (

)"

" () " ()
()

" () "

.(

:

"

)"

" (

)"

)"

" (

":

(

)"

.(

.

:



" (:)

()"

)" "



" (:)

()

" (:)

"

.()

:

" :

) "

.(

()

.

.

)

(

出
發

" : 發

) "

. (-

الباب الثالث

**بعض النماذج على دراسات تطبيقية
في مجال الاقتصاد الإسلامي**

الفصل الأول

بعض مرتكزات التنمية الاقتصادية
للمجتمع الإسلامي نظرة تحليلية
لبعض الدراسات غير العربية^(*)

(*)

- - ()

.

()

-

-

.

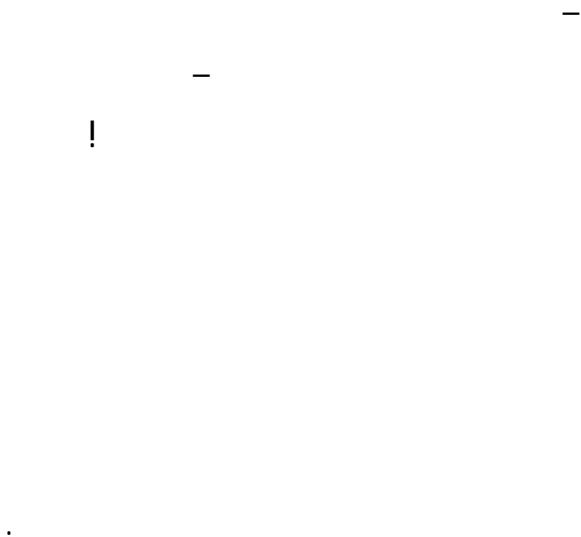

.

•

•

.

•

•

.

:

.

- -

:

) (

) (

(

) (

)(

(:) (



.(:)



.(:)

.

.

:

:

Power

Zillur khan, , .

pp - .

- -

secular

!

)

-

.(

(Dr.

.ZillurR.khan, , pp -)

()

" : ﷺ

! :

) ."

.(

(Muhammad Nejatullah Siddqui ,P)

:

)

()

(

()

()

()

.

.

:

.

" "

()

.

(Muhammad Abdul Mannan, , pp,

–)

–

–

()

(

–

–:

()

()

()

()

)

.(

)

() (

-

.

)

(

.

.

—

.

.

) ()

(

()

.

-

-

.

)"

"

.(

.

()

. ..

.

(-)

"

()"

- -

.

.

)

(

:

":

.

!

!

: !

:

: !

:

.()"

C.H.

Becker

.

()

- -

()

. (Maxime Rodinson, P.)

"

) "

(

"

) " ..

.(

" :

) "

.(

()

()

.

..()

- -

-

-

界

界

界

界

.(:)

:

:

(Association Muslim Social Scientists, , P.
)

"Dilemma" ()

.

-

-

.

()

!!

-

-

-

-

.

()

-

-

.

)

(Abdul Hamid A.Abu

Sujaman; , pp -



.
☾ : - -

(:) ☾

:



*

*



.(- :)

()

☾ : .

*



.(:)

-

(-)

-

.

.

⤵ :

⤵

.(:)

"

"

"Maxime Rodinson, , P "

(John Thomas

Cummings al, , pp)

.

..

!

()

()

!!

()

Conflicts

)

(

-

-

-

-

!!!

()

" "

...

" "

" " ()

!

" "

!

-

-

:(

)

3/20

"

":

!

":

"

.(

)

Globalization" " "

— —

“ ”

..

..

..

..

—

—

!!

- -

☾ :

☾ :

(:) ☾

.(:) ☾

-

.

- -

:

-

-

:

"

"

"

"

.

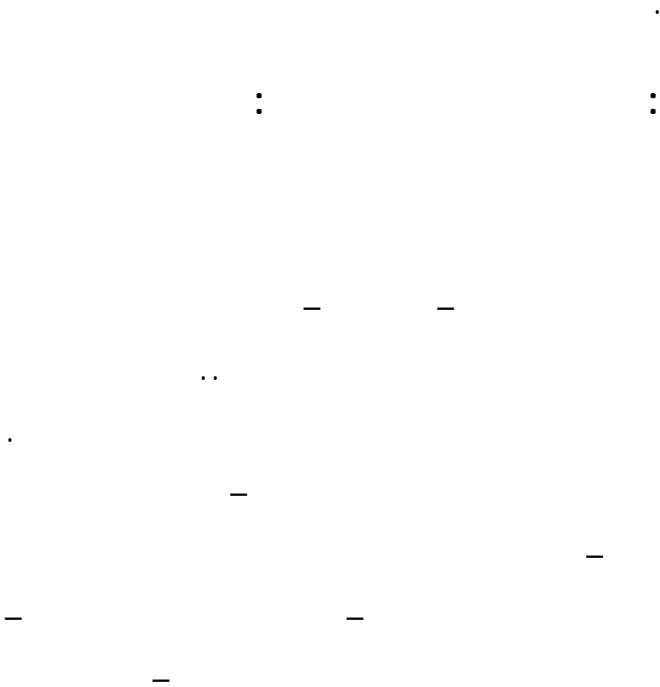

)

(

)

:

.(

()

(Jafar Shykh

Idris, pp. -)

.()

-

-

-

-

.

)

.(

"

"

.

)

(

.

..

" "

" "

..

- -

-

-

.

.



*

- :) ☾

.(

(Zillur

Rahman Khan, , pp. -)

()

.

(Masudul Alan, Chowdhury,

: , -)

..

.

.

-()

:-

-

.

:-

-

"

... "

.

-

-

-

-

" "

" "

"

" :

.

)

.(

-

.

-

(Mohammad Ngatullah

Siddiqi, , p)

- :

-

-

-

-

-

.

.

()

()

Motivation

-

.

-

-

)

-

(

:

) .

. (Khurshid Ahmed, , ps :

.

:

:

..

-

-

-

.

.

.

(Khurshid Ahmed,

, pp/ -)

.(..)

-

.

-:

-: Sovereignty - : -

.

- : -

.

- : -

.

()

(Umer Chapra, ,

-)

-

-:

-

"

"

-

-

-

) .

.(

()

-

.()

-

.

.

()

)

.(

()

)

" " (" "

.

.

)

-

(

as a way of life " "

(khurshid Ahmed, ,

.)

"Siddiqi"

leisure

"Hameeduallah"

)

(

(Muhammad -

Nejatullah Siddiqi, ,pp -)

-:

)

.(

:

.(

.

)

.(

-

:

-

)

-

-

-

()

.

-:

-

)

.

-

()

" "

) Upper limit

) Lower limit (

:)
(Khurshid Ahmed, , p

-

(John Thomas et al, , p)

virgin land

"

"

.

..

-

(Umar Shapra, ,p)

" "

self employment

)

.(

()

()

" "

.

)

%

.(%

.

(-)

rate of

rate of interest

return

)

(

)

.(

)

(

" "

.

(Kurshid Ahmed, ,

p)

)

)

(

(

(Umer Shapra,

.)
)
,p)

- -

!

(John Thomas

Cummings et al, , pp -)

()

- - .
-

(-)

)

(

()

- -

(Muhammad Nej-

: atullah, ,p)

-

-

.

.

.

||

||

.

" " (-)

)
" " ((" "

- -
)

(:)

"

.

"

•

•

.

.

()

)

":(

"

(" ") " "

" "

" "

" "

·
" "

·

" :

) "
.(

-:

-

()

.

-

..

!!

-

.

()

()

() -

() -

() -

()

() -

() -

()

"

. -

"

" ()

"

. -

()

-

()

. -

()

. -

:

()

-

()

-

()

-

Dr. Abbas Mirakhor and Iqbal Zaidi, (), "Stabilization and Growth in open Islamic Economy", in:

Abulhasan Muhammad Sadeq, (), Economic Development In Islam, Pelanduk Publications, Malaysia.

A.B.M Masudul Alam Chowdhury, (), "Efficient Allocation of Resources in An Egalitarian Educational System", in: Islam And Development, The Association of Muslim Social Scientists, Plainfield, Indiana.

Abul Hasan Muhammad Sadeq, Ataul Huq Pramanik, Nik Mustalha, bin Hj. Nik Hassan, (eds.), (), Development And

Finance in Islam, International, Islamic, University Press, Malaysia.

Association of Muslim Social Scientists, (), "Outlines of Islamic Economics" Proceedings of the first Symposium on The Economic of Islam in North America, Indianapolis, Indiana.

Abdul Hamid A. Abu Sulayman, (), "The Islamic Theory of International Relations: New Directions For Islamic Methodology And Thought", Islamization of Knowledge Series, No , The International Institute of Islamic Thought.

Dr. Ilyas Ba-Yunus, (), "Development And the Internal Dynamics of The Muslim State" in: Islam And Development, Proceedings, of The Fifth Annual Convention of the Association of Muslim Social Scientists, The Association of Muslim Social Scientists, Plainfeld, Indiana.

Dr. Ijaz Shafi Gibni (), "The Political Context of Islamic Economics: High And Low Road Strategies" in Khurshid Ahmed,

Economic Development in an Islamic Framework, International Center For Research in Islamic Economics, King, Abdul Aziz University, Jeddah & The Islamic Foundation, U.K.

Hohn L. Esposito (ed.), (), Islam And Development: Religion And Sociopolitical Change, Syracuse University Press, Syracuse, New York.

Dr. Jafar Shakh Idris, (), "The Islamic Way of Developing Nations" in : Islam And Development Proceedings, Of The Fifth Annual Convention of The Association of Muslim Social Sientists, The Association of Muslim Social Scientista, Plainfield, Indiana.

John Tomas Cummings, Hossein Askari, And Ahmad Mustafa, (), "Islam And Modern Economic Change" in: John L. Esposito (ed.)O, (), Islam And Development: Religion And Sociopolitical Change, Syracuse University Press, Syracuse, New York.

Khurshid Ahmed, (), "Economic Development in an Islamic Framework" in: Khurshid Ahmed, (ed.), Studies In Islamic Economics, International Center For Research in Islamic Economics, King, Abdul Aziz University, Jeddah & The Islamic Foundation, U.K.

Dr. Muammed Uzair, (), "Some Conceptual & Practical Aspects Of Interest-Free Banking" in : Khurshid Ahmed, (ed.), Studies In Islamic Economics, International Center For Reseaech in Islamic Economics, King, Abdul Aziz University. Jeddah & The Islamic Foundation, U.K.

Muhammad Nejatullah Siddiqi, (), "Islamic Economic Thought Foundations, Evaluation And Needed Direction" in: Abul Hasan Muhammad Sadeq, Ataul Huq Pramanik, Nik Mustapha, bit Hj. Nik Hassan, (eds.), (), Development and Finance in Islam, International, Islamic, University Press, Malaysia.

Muhamad Abul Mannan, (), The Making of Islamic Economic Society: Islamic Dimensions In Economic Analysis, 1st edition, International Center For Research in Islamic Economics, King, Abdul Aziz University, Jeddah.

Dr. Muhammad Nijatullah Siddiqi, (), "Economic Enterprise In Islam", Ishaat-e-Islam Trust Publications, No. 1, Markazi Maktaba Islami, Delhi-110002.

Dr. Muhammad Nejatullah Siddiqi, (), "Muslim Economic Thinking: A Survey of Contemporary Literature" in : Khurshid Ahmed, (ed.), Studies In Islamic Economics, International Center For Research in Islamic Economics, King, Abdul Aziz University, Jeddah & The Islamic Foundation, U.K.

Maxime Rodinson, (), Islam And Capitalism Penguin Books Ltd., Middlessex, U.K.

Dr. Umar Shapra, (), Islam And Capitalism, Penguin Books Ltd., Middlessex, U.K.

Dr. Umar Shapra, (), "Economic Development In Muslim Countries: A strategy For Development In The Light of Islamic Teachings" in:

Dr. Umar Shapra, (), "Towards An Islamic Financial System" in: Abul Hasan Muhammad Sadeq, Ataul Huq Pramanik, Nik Mustapha, bin Hj. Nik Hassan, (eds.), (), Development And Finance in Islam, International, Islamic, University Press, Malaysia.

الفصل الثاني
قراءة إسلامية لنظرية مالتس في
السكان^(*)

(*)

/

-

-

-

-

.

.

.

:

-

1

2

3

4

5

6

7

8

9

10

11

12

13

14

15

16

17

18

19

20

21

22

23

24

25

26

27

28

29

30

31

32

33

-

-

.

.

:

:

:

.

"

()

()

)

.(

)

(

)

(

.()

.

.

Rt – Malthus

.()

)

.(

- -

:

:

:

.

:

.

:

-

)

(

()

.()

:

. - - - - - :

- - - - - :

)

.("- "

:

Checks & Obstacles

:

Positive Checks

()

Preventive Checks

()

:

-

-

Moral Restraint

-

.Contraceptions

-

:

-

-

-

-

-

-

-

-

-

-

-

.

-

-

-

-



- -

:

- -

.

- -

.

- -

.

.

)

-

.(-

.

:

- -

- -

/ / .

- -

.

:

:

:

). .

. (

()

.

.

:

-

⌋ :

-

⌋

.(:)

*

⌋

.(:) ⌋

*

.

業

: .

":

)"

.(

:

業

:

"

.(

)."

業:

業

.(:)

業

業

.(:)



.(:)

:
)

(:)

:
)

:)

.(

.

()

":

۳۳۳

:

.()"

...

":

"...

.()

:

":

... ()"

"":

": ()

.()"

:

:

-

-

:

.

:

:



..

) 

.(

()



-

-

:
:

:
:

.(:)

.(:)

)

(

(

)

) :

:)

.(

" :

游

)"

:

.(

:

: .

游

...(

)

游

:

" :

游

) ."

.(

游

" :

: 游

.

:

:

.

.()"

...

:

: ...

:

"

:

)

...

.(

..

" :

"

"

.()"

)

:

(

*

...

*

- :) (

.(

⌋ :

*

:) (

.(

.

)

(

:

:

.
:)

-

(

-

:

:

"

"

.

"

"

"

"

.

:

:

.

:

:

) -

.(

) -

.(

) -

.

) -

.(

: :

.

" "

." "

:

.

()

"

.()"

" : ^{المعنى} :

.()"

" :

()"

."

" :

" ^{المعنى} :

:

:

()

:

:

.()"

-

-

.

.

" "

:

)

.(-

-)

- - (

..

: ۱۳۸۳

"

"

)

"

"

"

" : ۱۳۸۳

)"

.(

)

(

" :

:

."

()

)

)

(

(

.

"

⌘

" :

"

" :

" :

⌘

.(

)"

"

"

⌘

) ⌘

*

⌘

)(

(-
.(-

.

:

- -

.

)

.(..

.(..

:

☾ :

.(:) ☾

.

"

()"

)

.(

"

)"

(

" : ۱۳۸۳

- -

)"

":

.(

۱۳۸۳

۱۳۸۳

:

.

:

.

:

.

:

۱۳۸۳

.(

)"

":

.(

)"

" : 2016

.() "

" :

2016

) "

(

-

.

" "

" "

-

" "

" : " "

"

)

:

(

()

.()

-

-

.

)

.

(

.

.

- -

:

.

"

"

—

—

"

"

.

"

"

.

.

"

"

"

"

.

" ()

-

-

."

:

)

()

(

.

.

.

:

-

-

.

:

:

) :

.(:)

)

.(:)

)

.(:)

) :

:)

*

.(

()

)

. (:) (

) :

*

*

*

*

*

. (- :) (

-

.

-

()

:

"

"

"

()"

):

(:)

":

)"

):

.(

⌋

.(:)

.

)

(

☾ :

.

☾

☾ . (:)

:) ☾

.(



.

" :

: 𐎎𐎏𐎗𐎙

𐎎𐎏 : 𐎎𐎏𐎗𐎙

"

) 𐎎𐎏

.(

" :

" "

.()"

)

(

)



.(

) . (:) (

) . () (

. (:) (



. (:)

:

.
: () :

)

.(-

(

)

.(

()

.
—

—

.

:

:

()

:

) (

)

.(

)

.(

" "

.

)

.(



.(:)



.(:)

)

.(



*

.(:)

)

.(:)

) :

)

(:)

)

.(/



.(:)



.(:)



*

*

.(- :)

⌋

⌋

"

"

.

). :

:

.(

:

()

:)

⌋

.(



.(:) (

) :

.

:) (



.(

:) (

) .(

) .(:) (

*

) (:) (

) .(:) (

:) ☾

.(

:

:

:

()

"

"

.

-

()

()

:

:

()

:

☾ :

*

*

.(- :)



.(:)

(:)
.



.(:)



(:)

*



*

﴿ (- :) ﴾

(:) ﴿ ...

" : ﴿

:) "

.(

*

﴿ :

﴿ (:) ﴾

﴿

.(::) .(:)

. ﴿

﴿

" : ﴿

:) "

.(:) .(

" : 𐄂

) "

) :

.(



.(:) 𐄂



.(:) 𐄂



*

*

.(- :) 𐄂

:

()

:

☾ :

.(:) ☾

—

.

—

—

—

:

.

☾

) (

.(:

:) (...

) :

.(

) :

.(:) (

)

:) (

.(

()



.

.

:

- -

()

.

.

.

:

:

:

()

-

-

,

,

%

.(

)

()

جدول (۱)

(-)

()

-

()

-

,

,

,

,

,

,

,

· ,

· (-)

()

·

()

:

()	()						
							()

: - () : . ()

Statistical Year Book, , Table (), p. .

: - ()

The State of World Population, (), UNFPA
(United Nations Population Fund). New York.

" " ()

							()
							()
			,	,	,	,	
)

() ()

()

.

(-)

()

(-)

() ()
() ()

--- , ---

()
()
()
()

World Almanac And Book of Facts, , pp -

()

()

()

()

()

()

,

,

()

()

()

()

,

,

,

,

()

()

)

(

)

(

. ()

()

)

(-)

:

(

(-)

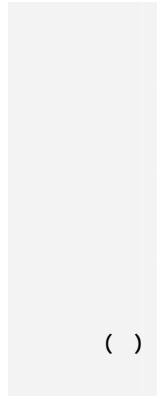

:

()

-

()

.

()

.

-

-

.

)

(

.

)

(

.

:

:

(.)

)

(-

-

(

.

()

.

" "

" " "

"

.

-

-

.

%

.()

%

-

-

" "

%

)

.(

"

)"

.(.

-

-

.

-

-

)

.(-

)

.(

.

.

-

-



.(:)

-



.(:)

...
.(:).....

.

- -

.

:

- -

-

)

-

.(

.

-

-

)

(-

)

(

()

.

"

"

"

"

-

-

— —
.

— —
.() .
—

()

- -

)

.(

)

(

)

.(-

.

-

-

.

•

•

.



.(()

-

-

-

.

:

"

"

.

)

.(

()

. -

(-)

-

.

-

-

.() ()

-

()

-

.

(-) -

: () -

()

() . -

()

-

-

-

" () . -

:

"

-

()

-

-

-

()

. -

()

. -

)

-

-)

(

(

()

-

() -

-

() -

() UNFPA -

() UNFPA -

(-) -

-) -

() (

()

. -

.()

()

()

-

.

" ()

-

"

-

.

()

-

.

-

.

- . Britannical Book of The year, (), Encyclopaedia Britannica Inc.
- . Ganzin M., (), Mineral Handbook, M. Stockton Press, New York.
- . Ganzin M., (), "Pour entrer dans ere Justice alimentaire" UNESCO Courier, Cited by Susan George, How the Other Half Dies, Benguin, Harmonds Worth, .
- . Lowry J.H., () World Population and Food Supply, Edward Arnold Ltd, London.
- . Malthus, T.R., (), Principles of Political Economy, Considered With a View to Their Application, nd ed., Basit, Blackwell, Oxford.
- . Omran. A. R., (), Family Planning in the legacy of Islam, Published with the Support of the United Nations Population Fund, London & New York.
- . Statistical Year Book, .

- . The State of World Population, (), UNFPA (United Nations Population Fund), New York.
- . United states Department of Agriculture, (), Economic Research Service, World Agreculturesituation And Outlook Report, Washington, Dc.
- . The World Fact Book, (), Central Intelligence.
- . World Almanac And Book of Facts, ().

الفصل الثالث
تقييم اقتصادي إسلامي نظري لسوق
التأليف العلمي / الديني

" " " "

. ()

" "

.()

)

.(

()

()

.

:

()

..

..

.

:

.

-

-

-

.

.

-

.

:

() ()

.

:

./

:

:

.-

:

. /

:

. /

/ - -

: :

() ()

() -

.

()

() ()

☞ :

» (:) «

.(:) «

» : ()

(:) «

» ()

.(:) «

)

(-

:

.

()

- ..

. ()

-

..

.

()

)

()

(

()

()

()

()

..

()

.

..

.

.

.

()

.

☾ :

(:)

- -

.

() ()

.

()

"

"

.

- -



:)



.(:)

()

()

"

"

/

:

:

:

() ()

"

)"

.(

..

()

..

.

:() ()

:" " :

) ()

(

.(

.

.

) ()

(

)

.(

-)

/

.(

) ()

(

"
الملك
يوسف

)"

.(

) ()

(

"

)"

.(

.

) ()

卷

(

"

) "

.(

) ()

:

(

"

() "

(

" : 卷

) "

.(

...

.

/

:

:

/

)

(

.

-

-

)

.(

/

-

-

/

.

()

-

...

" "

.

/

:

".

)"

.(

:

:

()

.

"

"

)

":

(

)"

.(

.

":

)"

.(-

:

()

/

/

-

":

۱۱۱۱
۱۱۱۱
۱۱۱۱

) /

)"

: (

) ()

.(

()

" :

) "

) (" "

(

" :

-)"
.(

() ()
()

..

.

..

()

.

()

()

"

)"

) (

.(

.

()

"

- : (

.

- -

: /

-

.

()
.()

..

()

.

..

() ()

() ()

()

()

. ..

/

.

:

:

:

:

/

:

()

..

.

: ()

..

..

.

()

..

..

..

.

()

.

()

-

..

.

()

..

.

()

.

-

()

)

(

.

()

.

:

:

:

-

-

:

()

)

:

(

:

-

:

()

.

..

.
:
()

)
(

-

.
:
()

.

·
:

()

-

.

:

()

)

(..

.
—

()

—

—

—

()

.
() () ()

()

()

()

()

()

()

-

!

()

..

. ..

()

.

-

-

:

-

.()

()

-

() -

-

-

-

-

-

..

-

-

•

:

-

..

.

-

.

-

.

-

-

-

()

...

.

-

..

..

.

..

.(.)
-

.

()

:

: ()

.

Start Up Costs ()

.

Development Costs ()

()

Operating Costs ()

) ())

(() ()

)

(..

:

Shared Costs ()

) ... Correctors

.(

Marketing Costs ()

)

) (

) (

()

()

..

..

..

.

/

/

.

- -

/

.

/

/

-

-

-

.

.

:

: /

-

()

()

.

()

.()

()

()

..

.()

.

:()

()

() ()

..

() ()

-

-

.

/

-

-

.

-

.

-

۲۰۲۳

)

.()

(()

:(

)

()

.

:

:

-

.

:

-

-

-

. /

:

-

/

.

/

() ()

.

()

.

:

-

()

)

()

(

()

.

-

:()

-

() ()

.

. ()

.

)

(

.()

:

/

/

()

())

-

-

-

..

-

.

-

.

-

()

..

()

..()

()

!!!

()

.

:

: /

()

)

..

(

.

.

()

()

()

()

-

-

-

.

-

()

()

-

()

)

(

—

—

.

—

—

.

.

:

!!

:

"

—"

" "

.

—

.

()

.

()

. ()

-

()

()

.

-

() :

() ()

(

..

.

:

:

()

()

-

..

-

-

"

"

)

.(

:

()

· : ()

· : ()
() ()

)

(

)

(

-

-

()

.

-

:

()

.

)

(

)

!!!

..

:

()

-

-

-

..

..

.

-
-

()

-

()

-

(-)

-

"

"

-

.

-) . . -

(

() -

//

//

(-) -

(-) -

()

(-) -

-

- Prof. Dr. Gabr Metwally, Prof. Dr. Mohamed El-Hady, Dr. Ahmed El Tobgy, Prof. Dr. Mohamed El- Mosallami, Prof. Dr. Nabil Amed, (), Cost. Effectiveness of Schistosomiasis Control Strategies in Egypt, Conducted by Department of community medicine Faculty of Medicine, Al-Azhar University.

* * *

الفصل الرابع
الأهمية الاقتصادية والاجتماعية
للصدقات التطوعية*

()

-

-

-

Macro

)

.(..

)

(

()

.

-

-

.()

-

-

.

.

:

.

:

.

:

- -

)

(

.(

)

.

:

()

.(.)

:

-

-

.

.

- -

" :

:()

"

(

.)



.(:)

-

-

-

-

.

:

:

Choice

() .

()

.

-

-

.

:

.

-:

: ()

☾ :

(:) ☾

☾ :

.(:) ☾

" :

) "

.(

-

-

)

.(

.

.)

-

(

" :

) "

-

(

" :

:) "

.(

-

.

: ()

-

-

.

:

" : 2008

) "

.(/

)

(

" : 此

) "

.(

:

()

-

-

-

-

-

" : 此

) "

.(/

- -

ﷺ

) "

.(/

" :

) "

.(

.

:

" :

)"

.(

-

:

:

"

:

:

:

)"

.(

.

()

:

":

:

:

:

:

.

:

:

:

.

:

:

.

)"

.(

.

" : 家

(

)

.()".

()

-

-

-

-

- -

.

:

:

-

-

-

.

)

(

:

..



(:)

:
:

()

(:)

":

)"

(

-

":

)"

.(

-

" : 業

) "

.(

-

-

" : 業

) "

.(

:

.

" : 業

:

) "

(

: . : . " : 齋

: . : .

. . : .

: . : . :

) " : .

.(

齋

" :

) "

.(



:

:

:

.()" "

306

" :

" :

:

: .

."

" :

-

-

()

-

-

-

)"

.(

۱۳۸۶

" :

:

)"

: .

.(

.(

)

" : ۱۳۸۶

:

—

—

.()"

⋮

:

" ⋮

:

()"

(.)

.

)

⋮

" :

.(

⋮

:

:

.

:

⋮

)"

.(

()

.



*

*

*

-

:

)



*

(

.

()

*

:



*

.(- :)

:

:

.

:

()

" - : ۱۱۱۱۱۱

-

-

) "

.(

-

☾ :

. (-) ☾

- -

.

.

-

-

()

-

此

”：

：

.()”

-

-

-

-

-

”：

：

此

)

" : (

) "

.(

-

" : *الحمد لله*

) "

.(

-

" : *الحمد لله*

) "

-

.(

.

" :

:

.) (- -) "

. . -
()

" 游
) "

.)

游

":

)"

.(

()

()

-

-

-

-

-

-

.

.

()

:

ﷺ

)"

.(

()

-:

- -
.

☾ :

) ☾

.(:

)"

"

(

)"

-

.(

:

":

"

)

-

()

(

"

)"

.(

-



.(:)

" .

)"

.(

:)

)

).(

.(:)

...)

)

)

.()

()

.

"

"

"

)"

.(

"

)"

.(

"

:

)"

.(

"

)"

.(

-

-

.(

)

-

-

":

-

:
)"

.(

- -

-

-

-

.

-

.

:

-:

.)

% ,

(

.

% ,

.

% ,

)
(
)
(
%
-

.
% ,)
% ,) (% ,
% ,) (% ,
. (% ,
.

.()

(% %) ,

,

,

.

, (!) ,

% ,

/ % , /

.()

/

,

/

,

.

.()

-

-

,

,

.)

.(

.

)

.(

/ %

%

-

-

.

-

-

()

-

.

..

) !!

.(

:

:

:

:

- -

. /

,

,

).

% ,

.

, (/ - /)
.(% ,)
(,)

,

,

,

-

-

,

.

)

.(-

-

-

)

.

.

..

.() ()

()

.

%

)

. -

.()

)

(-

.()

()

() / - /

()

() ()

/	/	/	/	/	/	/	/	/	/	/	/	/	/	

: () ()

: - ()

		-	-	-	-	-	-	-	-	-	-	-	-

/

/

.

-

- / - /

()

/

. /

-

-

.

(- .)

.

.

-

..

.

: /

-

.

-

.

-

.

-

.

-

% ,

.

-

.

/

% ,

.

..

..



-

.

:

:

)

(

.

)

.(

-:

-

-

-

)

(..

-

-

)

(

-

-

()

.

.

-

-

.

.
- -
:
:
: !!
:
.) .
. (-
)
" " " ()
Basic Needs "
()
-
" " " "
"

(ILO)

. (-)

.

-

-

*

)

(:)

.

Micro

() ..

Macro

.()

—

"

"..

)

—

.(

"..."

"

..

..

-

()

.

.

.

) () ()

(

.

)

(

:

.

)

(

)

-

-

.(:) (

)

()

-

-

-

-

-

-

☾ :

(:) ☾

.

—

—

()

()

.

()

.

- -

- -

.

()

-

-

"

"

()

.

)

-

.

()

.
.()

.

:

:

()

-

()

.

":

)"

(



.(:)

:

. :)

.(-

()

()

306

:

"

" :



.(:)

)

):

(

.(

.
":

()

(- .)" "

" :
)"

. : - -
.(

.

.

-

-

-

)

.(..

.

-



.(:)

()

()

.

)

.

(-

.

)

()

(

(

)

.

-

)

-

.(

Trade off

...

-

.

()

.

.

()

:) .

-

./ /

.(-

-

.

-

-

)

.(..

. ..

- -

)

: (

.)/

.(- -

- : ((

)

(

.

)

()

.

:

.

:

()

-

-

.

()

.

.

.

-

.

-:

-

()

()

.

-

.

-

.

-

()

-

-

-

()

()

. . -

/

.

-

/

.

.

-

.

-

.

. / -

. / -

. / -

" / -

" / -

- / -

:" / -

" / -

" / - /

" /

" (/)

/

.

:

.

/

-

-

-

.

.

:

()

- ○

- ○

- ○

() () -

-

() -

- () -

-

-

-

)

-

-

(

-

.()

()

-

/

-

-

-

-

/

-

()

-

-

-

/

)

-

(/

.

-

-

.

/

-

.

-

.

-

.

-

-

.

-

-

.

-

" / -

"

- / -

-

/ -

" "

-

- /

.

-

"

" / -

-

.

-

"

/

-

"

/

-

/

-

.

-

()

.

-

.

()

()

)

/

-

-

-

-

-

-

	-
)	/
.	(/
-	-
	-
	-
	-
/	-
	"
.	-
(/)	-
.	-
()	-
.	-
.	-

/ -

()

/ -

/ -

/ -

()

-

