

# We are IntechOpen, the world's leading publisher of Open Access books Built by scientists, for scientists

4,400

Open access books available

117,000

International authors and editors

130M

Downloads

Our authors are among the

154

Countries delivered to

TOP 1%

most cited scientists

12.2%

Contributors from top 500 universities



WEB OF SCIENCE™

Selection of our books indexed in the Book Citation Index  
in Web of Science™ Core Collection (BKCI)

Interested in publishing with us?  
Contact [book.department@intechopen.com](mailto:book.department@intechopen.com)

Numbers displayed above are based on latest data collected.  
For more information visit [www.intechopen.com](http://www.intechopen.com)



---

# A Human Body Mathematical Model Biometric Using Golden Ratio: A New Algorithm

---

Evon Abu-Taieh and Hamed S. Al-Bdour

Additional information is available at the end of the chapter

<http://dx.doi.org/10.5772/intechopen.76113>

---

## Abstract

This research provides more than 35 measurements rules derived from the perspectives of Vitruvian Man and Neufert and their basis of the golden proportion, to build a human body model on computers for the use of multimedia. The measurements are based on 25 proportional rules derived from 15 proportions given by Vitruvian Man and 29 golden proportions in *Bauentwurfslehre* by Ernst Neufert. Furthermore, the research will suggest two algorithms to calculate the 67 measurements with precision; assuming that the algorithms output will be used as guideline to human body modelers in simulation, gaming, plastic surgery, as well as the world of biometrics or wherever human body measurements and calculations is needed like prosthetic limbs, spatial design, and machine learning of human biometrics. Furthermore, building proportional models creates visual harmony in measurements and visual parity model. Hence, the chapter facilitates and explains for the human modeler the process of human modeling from within an algorithm. This research is an expanded work based on two published conference papers listed in the references section.

**Keywords:** simulation, multimedia, computer, medial section, divine proportion, golden proportion, mean of Phidias, Neufert, human biometrics, divine proportion, multimedia, human modeling, machine learning

---

## 1. Introduction

This research is based on two published papers [16, 17] pertaining to same subject by the same author. The research identifies more than 35 measurements and proportions to be used in modeling a human body on computers. The 35 measurements rules are based on Vitruvian Man and Neufert descriptions of *Bauentwurfslehre* by Ernst Neufert [20] and Leonardo da

Vincicirca both based on the golden proportion notion. First, the research gives an introduction about golden proportion known also as golden section. Then, in the second section, the research explains the three dimensions of golden proportion: mathematically, geometrically, and arithmetically. The third section of the research presents the work of FIBONACCI and his series in the golden proportion. Followed by a discussion of the geometry of Golden ratio and the essential proportions in Vitruvian Man, in the fourth section, where 15 essential proportions are explained based on the Vitruvian Man. In fifth section, BAUENTWURFSLEHRE by ERNST NEUFERT [20] is further explained with circle geometry and 29 golden proportions are reflected in the work. In the sixth section, the face and hand proportions in relation to the golden proportion are further explained. Based on the findings of the previous sections, the seventh section suggests two algorithms to be used when building a human body model. Thereby, presenting more than 35 proportions and measurements used to model human body model along with a simple algorithm that calculates exact measurements. As such, the research facilitates and explains for the human modeler the process of human modeling in multimedia arena. Hence, this research will be a spring board for researchers, practitioners in human modeling in multimedia field.

Dubbed by the Greeks, “Golden Ratio” is a mathematical relation and proportion, where the length to width of a rectangle proportion is  $1:1.61803398874989484820$ , such proportion is most suited for human eye and is used by architects, artists, sculptures in their work. While the Golden Ratio does not embody every structure or pattern in the universe, yet, historically, this ratio emerged in Great Pyramid of Giza/Khufu/Cheops (2560 BC) [21], and in Vitruvian Man by Leonardo da Vinci and Neufert. More notably, in today’s multimedia, Golden Ratio is used in many applications: plastic surgery simulation software, animation software, art, architecture, sculpture, anatomy. A close exploration of such divine proportion and the related applications, offers opportunities to connect an understanding the conceptions of ratio and proportion to the geometry, proportions, and ratio related to the Vitruvian Man and its relation to Bauentwurfslehre by Ernst Neufert (1936) [20]. Throughout the next sections, a detailed explanation will be given to golden ratio: geometrically, mathematically, and arithmetically.

## 2. Golden ratio

Golden Ratio has many perspectives: geometrically, mathematically, and arithmetically. A full understanding of all perspectives as well as the origin of the term is essential, in order to grasp the magnitude from the microscale to the macroscale. In this section, *Golden Ratio* will be explained term and perspective wise.

The origin of the term *Golden Ratio* was termed by Phidias. Phidias is a Greek painter, sculptor, and architect. Phidias sculpted the famous Zeus at temple of Olympia, which was considered one of the Seven Wonders of the World. The *golden ratio* was termed *mean of Phidias* [6, 8, 15]. There are many terms that reflect the term Golden Ratio: *golden mean* [2, 7, 10] and *extreme/mean ratio*, (Euclid) *medial section* [3], *divine proportion*, *divine section* (Latin: *sectio divina*), *golden proportion*, *golden cut*, [11] *golden number* [6, 15, 8]. In current history, *Golden Ratio* was termed as

*Golden Section* (goldene Schnitt) by a German mathematician named Martin Ohm who lived from 1792 till 1872. Mark Barr coined the term ( $\phi$ ) to reflect the idea of *Golden ratio*, in commemoration of Phidias, because many historians [7, 13] claim that Phidias used the Golden Ratio in his sculptures.

Simply, *Golden Ratio* is a proportion of two unequal segments: the proportion of the long segment to the short segment is equal to the total of the two segments to the long segment, both equal 1:1.61803398874989. In **Figure 1**, the longer segment  $a$  and the short segment  $b$ , whereby the proportion of  $a:b$  is equal to the total of  $a$  and  $b$  to  $a$ . The number 1.61803398874989 is the value of  $\phi$ . In this context, the ensuing question is how to derive  $b$  from  $a$  while keeping the Golden Proportion,  $\phi$ ?

To derive the  $b$  segment from the  $a$  segment, the following must be conducted: First, draw a square with length  $a$ , as articulated in **Figure 2**, and construct a unit square. Then, at midpoint on the side of the square, draw a line to the opposite side. Next, connect the midpoint to an opposite corner. When using that line as the radius to draw an arc, accordingly, the long dimension of the rectangle is defined.

The simpler picture is reflected in **Figure 3** where the “ $a$ ” and the “ $b$ ” are shown and the both hold the value of  $\phi$ , the Golden proportion.

Concluding the section where the origin of the term *Golden Ratio* was not only clarified but thorough explanation of the geometrical aspect of the ratio was also put forward, in order to comprehend the magnitude of this proportion.

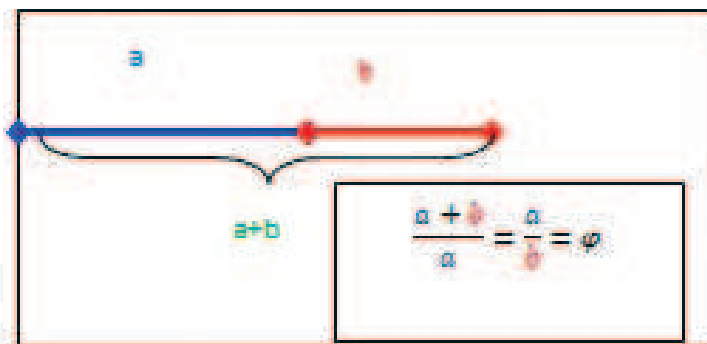

**Figure 1.** The *Golden Ratio* represented in line segments [3, 4].

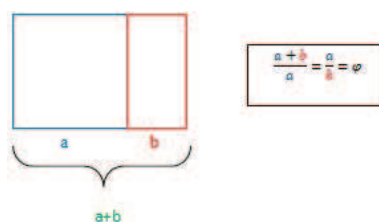

**Figure 2.** Construction of a golden rectangle.

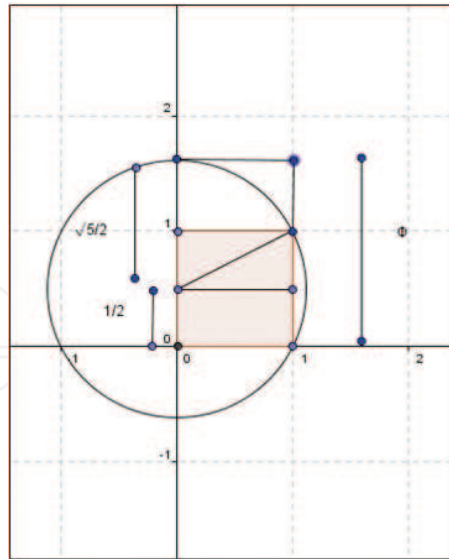

**Figure 3.** A golden rectangle with longer side  $a$  and shorter segment  $b$ .

### 3. The mathematics of golden ratio: Fibonacci series

In view that understanding the golden ratio mathematics is imminent, especially when it is reflected in the Fibonacci Series [2]. Another perspective is the how the *golden ration* interrelates with the square root of 5. The two perspectives are clarified in the next paragraphs. Accordingly, this section will discuss the mathematical properties of golden ratio ( $\Phi$ ), especially in Fibonacci series, while noting that  $\phi$  with small letter p is equal to 1.618033988749895, whereas  $\Phi$  with capital P equals 0.618033988749895.

Fibonacci series, named after Leonardo Fibonacci, is a simple series that when starting with 0 and 1, each new number in the series is simply the sum of the two before it. The ratio of each successive pair of numbers in the series approximates  $\phi$  (1.618). In fact, after the 40th number in the series, the ratio is accurate to 15 decimal places. Furthermore, the value of golden ratio ( $\phi$ ) is reciprocal to the value of golden ratio ( $\Phi$ ), noting that the ratios of the successive numbers in the Fibonacci series quickly converge on golden ratio ( $\Phi$ ), the ratio is accurate to 15 decimal places:

$$f_n = \Phi^n / 5^{1/2}$$

For example, the 40th number in the Fibonacci series is 102,334,155, which can be computed as (Table 1):

$$f_{40} = \Phi^{40} / 5^{1/2} = 102,334,155$$

Concluding this section, where the mathematical perspective of the Golden Ratio was illustrated through the Fibonacci Series and the relationship of the successive elements of the series that converge to the golden ratio.

n	$F_n$	$F_{n+1}$	phi	Phi
0	0	1	infinity	0
1	1	2	2	0.5
2	3	5	1.666666667	0.6
3	8	13	1.625000000000000	0.615384615384615
4	21	34	1.61904761904762	0.617647058823529
5	55	89	1.61818181818182	0.617977528089888
6	144	233	1.61805555555556	0.618025751072961
7	377	610	1.61803713527851	0.618032786885246
8	987	1597	1.61803444782168	0.618033813400125
9	2584	4181	1.61803405572755	0.618033963166707
10	6765	10,946	1.61803399852180	0.618033985017358
11	17,711	28,657	1.61803399017560	0.618033988205325
12	46,368	75,025	1.61803398895790	0.618033988670443
13	121,393	196,418	1.61803398878024	0.618033988738303
14	317,811	514,229	1.61803398875432	0.618033988748204
15	832,040	1,346,269	1.61803398875054	0.618033988749648
16	2,178,309	3,524,578	1.61803398874999	0.618033988749859
17	5,702,887	9,227,465	1.61803398874991	0.618033988749890
18	14,930,352	24,157,817	1.61803398874990	0.618033988749894
19	39,088,169	63,245,986	1.61803398874990	0.618033988749895
20	102,334,155	165,580,141	1.61803398874989	0.618033988749895
21	267,914,296	433,494,437	1.61803398874989	0.618033988749895
22	701,408,733	1,134,903,170	1.61803398874989	0.618033988749895
23	1,836,311,903	2,971,215,073	1.61803398874989	0.618033988749895
24	4,807,526,976	7,778,742,049	1.61803398874989	0.618033988749895
25	12,586,269,025	20,365,011,074	1.61803398874989	0.618033988749895
26	32,951,280,099	53,316,291,173	1.61803398874989	0.618033988749895

Table 1. Fibonacci series converge on Phi.

#### 4. Vitruvian man

Proportions used to model, paint, and sculpt a human body are essential, as [18] Luca Pacioli, a contemporary of Da Vinci, indicates that “without mathematics there is no art,” proportions are an integral part of design and beauty of nature, to achieve beauty, balance, and harmony, thereby presenting visual parity to the audience. According to [9], such use of proportion creates *the greatest harmony in the symmetrical relations*.

The use of proportions when drawing a human body is not new, in fact, Leonardo da Vinci suggested a 15 rules of proportions which will be discussed in this section. Also, Marcus Vitruvius Pollio (born c. 80–70 BC, died after c. 15 BC), named by Taylor in an article in The New Zealand Herald called Marcus Vitruvius Pollio “the world’s first known engineer” [12]. Marcus Vitruvius Pollio wrote his work *On Architecture* in 25 BC. In his book, he stated that *human body and a perfect building are similar* [1]. Furthermore, the use of proportion in buildings, paintings, and sculpting is not a new idea so is the use of human body proportions in buildings.

Leonardo da Vinci developed 15 proportion rules used to model a human in his work named VITRUVIAN MAN. The famous proportions were written underneath the illustration shown in **Figure 4**. The rules are further explained in **Figure 5** and in the list of proportions shown at the end of this section.

The first rule is that the length of a man is equal to the width of a man with both arms extended. Hence, a man can be inscribed in a square, as seen in **Figure 4**. A man can be inscribed in circle where the extended arms while raised to the level of the head and both feet are on the circumference of the circle, as seen in **Figure 4**.

The second rule is for the proportion of the face which is  $\frac{1}{10}$  of the man height. The third rule is for the head proportion which is  $\frac{1}{8}$  of man height. The fourth and fifth rules, from the chest to the hair line is  $\frac{1}{7}$ -man height, and from chest to the head is  $\frac{1}{6}$ -man height. The sixth rule pertains to the shoulders width, which is  $\frac{1}{4}$  of man height. The seventh rule measures the distance from breast to the top of the head and the proportion is  $\frac{1}{4}$  of the man height, noting

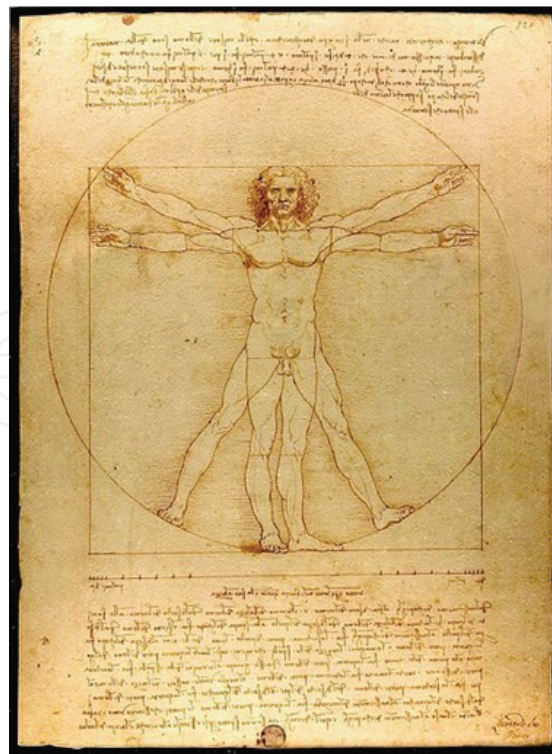

**Figure 4.** Vitruvian man by Leonardo da Vinci, Galleria dell’ Accademia, Venice (1485–1490).

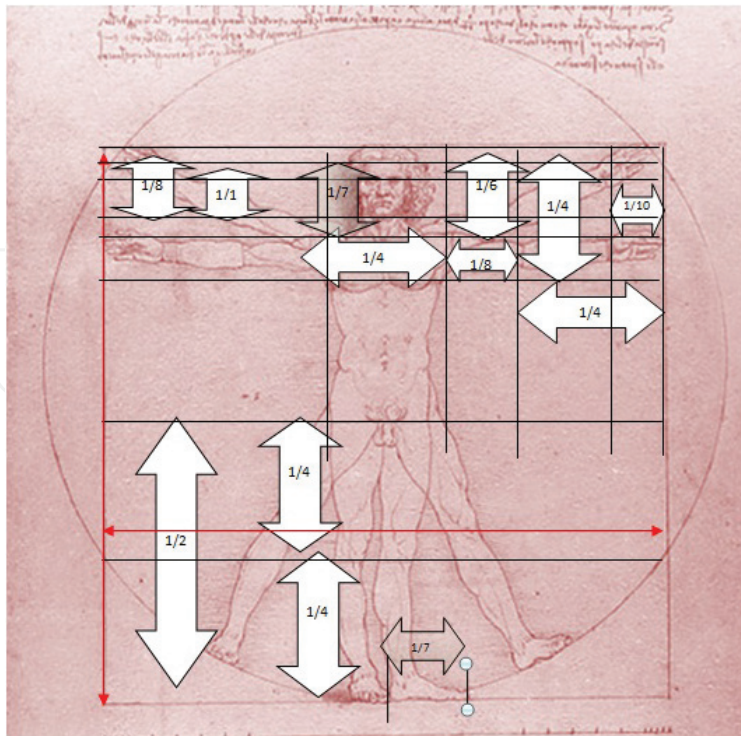

**Figure 5.** Vitruvian man with proportions suggested by Leonardo da Vinci.

that measurements from the rule 6 and 7 correlate. Rules 8–10 all relate to forearm, upper arm, and hand which are  $\frac{1}{4}$ ,  $\frac{1}{8}$ , and  $\frac{1}{10}$  height of a man, respectively. It is worthwhile to note that the aforementioned three rules on measurement of forearm, shoulders width correlate with rule 7. Rule 11 is the measure of half the man, from the root of the penis to the top of the head or the root of the penis to the sole of the feet is  $\frac{1}{2}$  of man height. Rules 12–14 pertain to foot leg and thigh. The foot is  $\frac{1}{6}$  of man height while the leg and thigh are both equal to  $\frac{1}{4}$  of man height. The last rule explains proportions used in the face which divides the face to three-thirds: one-third from hair line to eyebrows, second third from eyebrows to below nose, and from below the nose to end of chin. The last rule, pertaining to face proportions will be thoroughly discussed in Section 6 of this chapter. The original quote from Leonardo da Vinci work is in the research [16, 17].

In short, [5], the following table summarized the previous quote as illustrated in **Figure 5**.

1. The length of the outspread arms is equal to the height of a man.
2. *Face*: from the hairline to the bottom of the chin is  $\frac{1}{10}$  of the height of a man.
3. *Head*: from below the chin to the top of the head is  $\frac{1}{8}$  of the height of a man.
4. From above the chest to the top of the head is  $\frac{1}{6}$  of the height of a man.
5. From above the chest to the hairline is  $\frac{1}{7}$  of the height of a man.
6. *Shoulders*: the maximum width of the shoulders is  $\frac{1}{4}$  of the height of a man.
7. From the breasts to the top of the head is  $\frac{1}{4}$  of the height of a man.



8. *Forearm*: The distance from the elbow to the tip of the hand is  $\frac{1}{4}$  of the height of a man.
9. *Upper arm*: the distance from the elbow to the armpit is  $\frac{1}{8}$  of the height of a man.
10. *Hand*: the length of the hand is  $\frac{1}{10}$  of the height of a man.
11. The root of the penis is at  $\frac{1}{2}$  the height of a man.
12. *Foot*: is  $\frac{1}{6}$  of the height of a man.
13. *Leg*: from below the foot to below the knee is  $\frac{1}{4}$  of the height of a man.
14. *Thigh*: from below the knee to the root of the penis is  $\frac{1}{4}$  of the height of a man.
15. *Face*: the distances from the below the chin to the nose and the eyebrows and the hairline are equal to the ears and to  $\frac{1}{3}$  of the face.

In closing, this section attempted to shed light on the significance of using the divine proportions in design, beauty, and parity. Famous and profound painters, designers over the centuries have been influenced to use proportion when painting and sculpting human body; in this context, 15 proportional rules used by Leonardo da Vinci in drawing the Vitruvian Man was explicitly discussed, noting that proportion use was extended to be used in architecture and by architects like Marcus Vitruvius Pollio, which will be further discussed next. As such, proportion use in art is equally profound and archaic.

## 5. Bauentwurfslehre by Ernst Neufert

*Bauentwurfslehre* is a German word means *Architects' Data* a book authored by Ernst Neufert a German engineer. *Architects' Data* is reference book for spatial requirements. The author developed the book based on the previous work of Leonardo da Vinci with *golden ratio* proportions. In this section, the work of *Bauentwurfslehre* by Ernst Neufert is first explained. Then 29 proportional rules are derived to further the work of the algorithm that is being developed to provide 35 measures that helps building a human model.

The *Bauentwurfslehre* shown in **Figure 6** is the composed of 29 proportional measurements, named *m* (in small letter) and *M* (capital letter) used on a human model. Also, there are 12 circles to derive the proportions. Both the circles and the proportions will be explained in the next paragraphs.

The 12 circles are numbered to explain each and differentiate one from the other. To build the model in **Figure 6**, the following steps are done: (1) a square is sketched with height of the man as the height of the square as well as the width; (2) two lines are sketched from opposite corners to locate the center of the first circle (the biggest circle); (3) a second circle is drawn with center is the navel and the radius is extended from navel to perpendicular line drawn from hand rest to ground; (4) a third circle is sketched with the navel as the center, and the radius is distance from navel to perpendicular line extended from elbow to ground; (5) a fourth

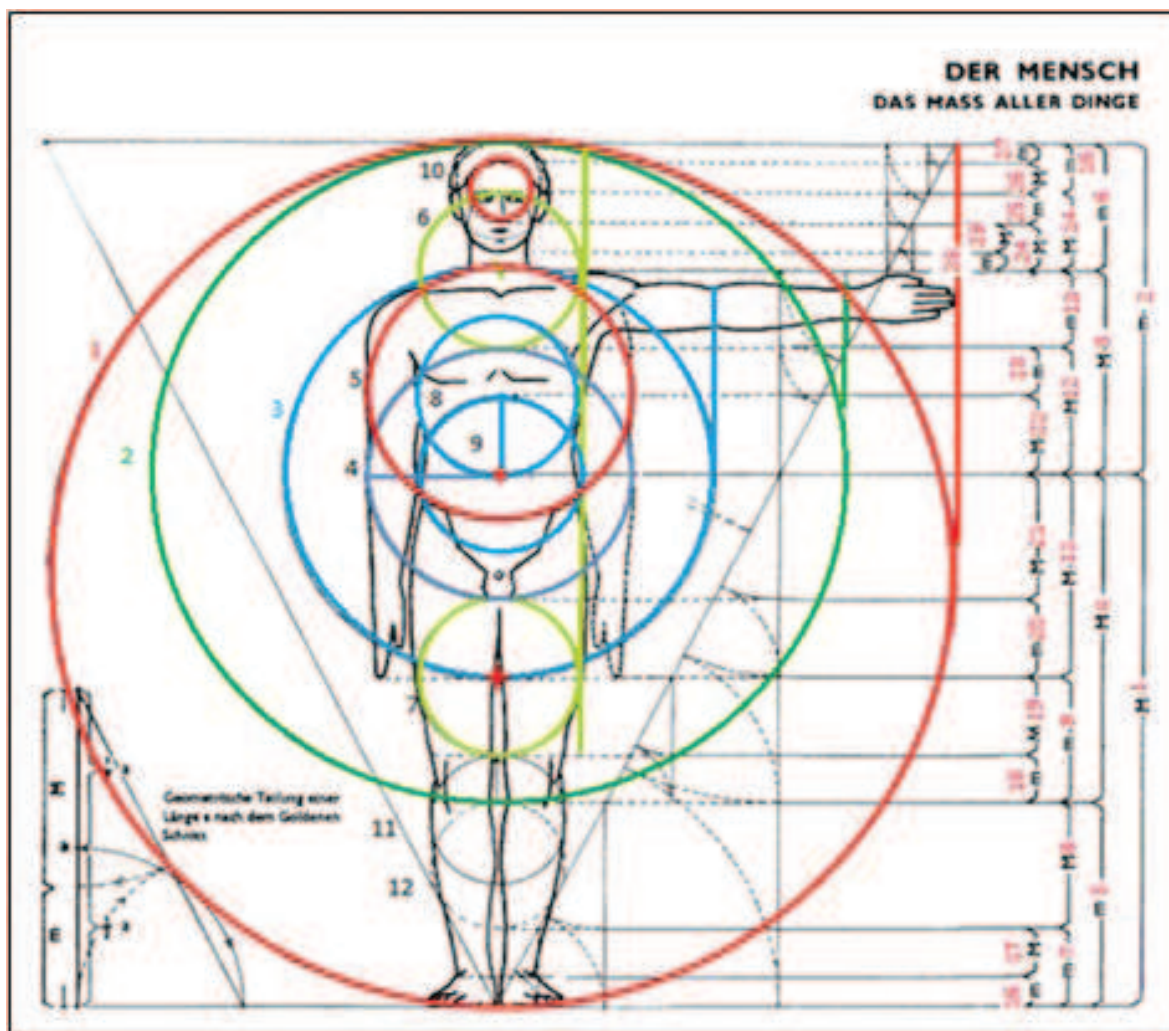

Figure 6. Bauentwurfslehre by Ernst Neufert (1936) [14].

circle is drawn with the navel as center and the radius from navel to the outer side of the arm; (6) a fifth circle is drawn with the center is mid-chest center, with radius outer arms; (7) a sixth circle is centered in the throat and the radius from throat to the line extended from shoulder to the ground; (8) a seventh circle is sketched with center in mid thighs and the radius is the outer side of the thigh; (9) an eighth circle is sketched and centered in the is mid-chest center, with radius inside arms.; (10) a ninth circle is sketched and centered in the navel and the radius is the sides of the middle section; (11) a tenth circle is drawn and centered in the point between the eyes and the radius is the sides of the face (temples); (12) the eleventh circle is drawn and centered to touch the seventh circle while reducing the radius to the outer side of the legs, below the knee, and finally (13) the twelfth circle is sketched similar to circle 11 while touching the second circle.

To explain the golden ratio from within the 29 measurements little *m* and big *M*, one must start with explaining the base case *M16*. The measurement *M16* is measured from bottom of foot to foot end (see Figure 7). *M17* is derived according to the golden ratio rule seen in (1):

$$\frac{M17 + M16}{M17} = \frac{M17}{M16} = \varphi \quad (1)$$

Furthermore,  $M7$  is the total of both  $M16$  and  $M17$  [see (2)]. In addition,  $M7$  is used to derive  $M8$  according to golden ratio rule as illustrated in Eq. (3). Note that the upper limit of  $M8$  is below the knee and it is the tangent of both *circles 12* and *2* (see **Figure 6**). Also, note that  $M3$  is the total of  $M7$  and  $M8$  as seen in Eq. (4):

$$M7 = M16 + M17 \quad (2)$$

$$\frac{M8 + M7}{M8} = \frac{M8}{M7} = \varphi \quad (3)$$

$$M3 = M7 + M8 \quad (4)$$

Again,  $M18$  is the measure of the knee, below knee to above the knee. The  $M18$  is used to derive  $M19$  according to rule in Eq. (5). The upper limit of  $M19$  is the center of *circle 7* and tangent to *circle 3* also, if a line drawn with the hand extended on the sides. In addition, note that  $M9$  is the total of  $M18$  and  $M19$  see (6):

$$\frac{M19 + M18}{M19} = \frac{M19}{M18} = \varphi \quad (5)$$

$$M9 = M18 + M19 \quad (6)$$

The  $M9$  is used to derive  $M11 = M9 \times 1.61803398874989$ . The  $M20$  is the measure of length of the hand (tip of figure to rest). The  $M20$  is used to derive  $M21$  according to golden ratio rule in (7). The upper limit of  $M20$  and the lower limit of  $M21$  is tangent to *circles 7* and *4* (see **Figure 6**). The upper limit of  $M21$  is tangent to *circle 8* and the center of *circle 9* and crosses the navel:

$$\frac{M21 + M20}{M21} = \frac{M21}{M20} = \varphi \quad (7)$$

The upper limit of  $M11$  is tangent to *circle 8* and the center of *circle 9* and crosses the navel. And  $M11$  is the addition of  $M20$  and  $M21$  (see **Figure 6**).  $M11$  is driven from  $M9$  according to rule in **Figure 3**:



**Figure 7.** Limit of  $M16$ .

$$M11 = M20 + M21. \tag{8}$$

The upper limit of  $M4$  is tangent to *circle 8* and the center of *circle 9* and crosses the navel.  $M4$  is the addition of  $M9$  and  $M11$  (see **Figure 6**). Also,  $M4$  is driven according to rules explained in **Figure 3** and as seen in (9):

$$M4 = M9 + M11 \tag{9}$$

$$\frac{M4 + M3}{M4} = \frac{M4}{M3} = \varphi \tag{10}$$

$$M1 = M3 + M4 \tag{11}$$

Once you reach the navel, one can easily calculate  $M2$  According to (12). The  $M27$  is from top of the head to hair line tip. The  $M27$  is used to derive  $M26$  according to rules explained in **Figure 3**. The lower limit of  $M27$  is tangent to circle 10, while the lower limit of  $M26$  is tangent to circle 6 and crosses the center of circle 10 (see **Figure 6**). Again, to derive  $M26$  apply:

$$\frac{M1 + M2}{M1} = \frac{M1}{M2} = \varphi \tag{12}$$

According to (13), the  $M2$  is the addition of  $M6$  and  $M5$ . Hence, both  $M6$  and  $M5$  can be driven from  $M2$  according to (14) and (15). The upper limit of  $M2$  is tangent for circles 1 and 2. The  $M2$  lower limit crosses center of circle 9 which is the navel (see **Figure 6**).

$$M2 = M6 + M5 \tag{13}$$

$$M5 = \frac{M2}{\varphi} \tag{14}$$

$$M6 = \frac{M2}{\varphi + 1} \tag{15}$$

The  $M6$  is from the base of the throat to the top of the head. Since  $M6$  is the total of  $M14$  and  $M15$  according to (16). Hence,  $M14$ , and  $M15$  can be driven according to (17) and (18):

$$M6 = M15 + M14 \tag{16}$$

$$M14 = \frac{M6}{\varphi} \tag{17}$$

$$m15 = \frac{M6}{\varphi + 1} \tag{18}$$

The  $M5$  is from the navel to the throat, the upper limit of  $M5$  is same level as center of circle 6. Since  $M5$  is the total of  $M13$  and  $M12$  according to (16). Hence,  $M12$ , and  $M13$  can be driven according to (20) and (21):

$$M5 = M13 + M12 \quad (19)$$

$$M12 = \frac{M5}{\varphi} \quad (20)$$

$$M13 = \frac{M5}{\varphi + 1} \quad (21)$$

The M12 is from the navel to rib cage, the upper limit of M12 is same level as tangent to circle 4. Since M12 is the total of M23 and M22 according to (22). Hence, M22, and M23 can be driven according to (23) and (24):

$$M12 = M23 + M22 \quad (22)$$

$$M22 = \frac{M12}{\varphi} \quad (23)$$

$$M23 = \frac{M12}{\varphi + 1} \quad (24)$$

The M15 is from eyebrows to top of the head, the upper limit of M12 is same level as tangent to circle 6. Since M12 is the total of M27 and M26 according to (25). Hence, M26, and M27 can be driven according to (26) and (27):

$$M15 = M27 + M26 \quad (25)$$

$$M26 = \frac{M15}{\varphi} \quad (26)$$

$$M27 = \frac{M15}{\varphi + 1} \quad (27)$$

The M14 is from the throat to eyebrows. M14 is tangent to circles 3 and 5 while the upper limit is tangent to circle 6. Note that, M14 is the addition of M24 and M25, and is derived according (29) and (30):

$$M14 = M24 + M25 \quad (28)$$

$$M24 = \frac{M14}{\varphi} \quad (29)$$

$$M25 = \frac{M14}{\varphi + 1} \quad (30)$$

The M24 upper limit will be tangent to *circle 10* and the lower limit is tangent to *circle 5*. M24 is tangent to circles 3 and 5 while the upper limit is tangent to circle 6. Note that, M24 is the addition of M29 and M28, and is derived according (32) and (33):

$$M24 = M29 + M28 \quad (31)$$

$$M29 = \frac{M24}{\varphi} \quad (32)$$

$$M28 = \frac{M24}{\varphi + 1} \quad (33)$$

This section explained 29 proportions and 12 circles used in Bauentwurfslehre by Ernst Neufert. The section first explained the work which is based on Leonardo da Vinci with golden ratio proportions. Then the research explained each circle's radius and center. Next, the research explained each proportion and how to calculate each ratio from M1 to M29. The findings of this section will be reflected in the algorithm suggested in Section 7 of this research. The next section will discuss the golden proportions used to model a human face and hands.

## 6. Face and hand proportions

The golden proportion is repeated in the human face and is used by plastic surgeons to follow as guidelines. Human face from the bottom of the chin to the hairline in length to the edge of the eyebrow is 1:1.618 or 1:  $\varphi$  as illustrated in **Figure 12**, the red rectangle. Likewise, proportion is illustrated in the same figure using the green rectangle; the green rectangle is edges of the eyebrows and the height is from the tip of the nose to the top of the eyebrows. The third golden proportion is seen in the blue rectangle. The blue rectangle extends from the eyebrow to the bottom lip, and from the space between the eyes to the end of the eyebrow. Based on the previous one can calculate the width of the face to equal 1: length of the face. The length of the face =  $M26 + M25 + M29$  and the length of the green box equals  $M25$  and the length of the blue rectangle is  $2 \times M25$ . Once the length is calculated, then the width can be easily calculated (**Figure 8**).

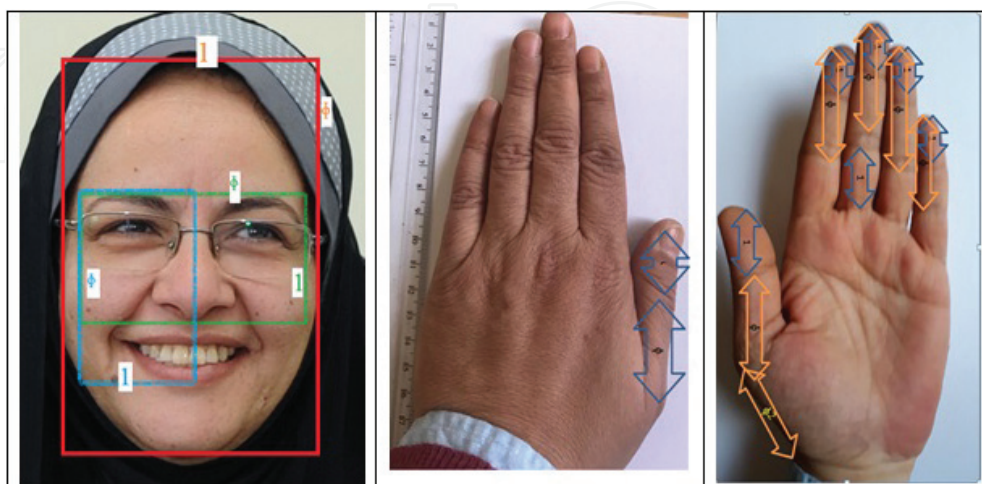

**Figure 8.** Face and hand golden proportions.

Gary Meisner [19] lists seven vertical golden proportions in the face and eight horizontal golden proportions. Next, the 15 proportions will be described based on Meisner's guide to beauty. The seven vertical golden proportions are: center of pupils to bottom of chin the golden ratio point is at center of lips, center of pupils to bottom of chin the golden ratio point is at nose at nostrils, center of pupils to nose base the golden ratio point is at nose flair top, top arc of eyebrows to bottom of eyes the golden ratio point is at top of eyes, center of pupils to center of lips the golden ratio point is at nose at nostrils, top of lips to bottom of lips the golden ratio point is at center of lips, nose at nostrils to center of lips the golden ratio point is at top of lips. Eight horizontal golden proportions are: side of face to opposite side of face, the golden ratio point is at inside of near eye; side of face to inside of opposite eye, the golden ratio point is at inside of near eye; center of face to side of face, the golden ratio point is at outside edge of eye; side of face to inside edge of eye, the golden ratio point is at outside edge of eye; side of face to outside edge of eye, the golden ratio point is at outside of eyebrow; center of face to width of mouth, the golden ratio point is at width of nose; side of mouth to opposite side of mouth, the golden ratio point is at cupid's bow. Meisner designated 33 points on human face as seen in [19], such points can be driven from the derived rules in **Figure 9**, namely *the length of the face =  $M25 + M26 + M29$  and the width of the face = length of face/1.618*. Since the width and length of face are known then Meisner's points (1, 33, 19, 20) can be calculated: Meisner's points (1, 33) are the upper and lower limit of the face height, respectively. Meisner's points (19, 20) are the left and right limits of the width of the face respectively. Meisner's point (15) = width of face/2.618 and Meisner's point (16) = width of face/2.618 both according to H1 and H2 in Meisner's work [19]. Meisner's points (13, 14) can be calculated as follows: Meisner's point (13) = width of face/(2 × 2.618) same for Meisner's point (14) = width of face/ (2 × 2.618). Meisner's point (7) = Meisner's point (13)/1.618 and Meisner's point (8) = Meisner's point (14)/1.618. Meisner's point (29) = width of face / (2 × 1.618) and Meisner's point (30) = width of face/ (2 × 1.618). Meisner's Point (24) = half width of face to Meisner's point (30)/1.618 and Meisner's point (23) = half width of face to Meisner's point (30)/1.618. Meisner's points (27,28) are cupid bow hence to derive them divide the distance from Meisner's point (29–30) over golden ration, Meisner's point (29, 30) = distance Meisner's point (29, 30) × 1.618. According to the previous 12 golden ratio rules were derived to the face vertically. Next, the same will be conducted to derive more rules horizontally. Again, since the height of the face is known, one can derive seven golden ratio rules according to Meisner [19].

First Meisner's points (19, 20) heights: Meisner's point (19) height = length of face/ (1 + 1.618) and Meisner's point (20) height = face length/ (1 + 1.618). Meisner's points (21, 22) are calculated from bottom as follows: Meisner's point (21) = face length/1.618 and the same for Meisner's point (22) = face length/1.618. Meisner's points (3, 4) measuring from bottom are face length/1.618, hence Meisner's point (3) = face length/1.618 and m Meisner's point (4) = face length/1.618. Meisner's points (11, 12) the center of the pupils are calculated as follows: Meisner's point (12) = difference of height between Meisner's point (20) and Meisner's point (4)/1.618 from top, and Meisner's point (11) = difference of height between Meisner's point (19) and Meisner's point (3) /1.618 from top. Meisner's point (31) is calculated as follows Meisner's point (31) = from Meisner's point (11, 12) to Meisner's point (33)/ (1 + 1.618). Meisner's points (23, 24) are calculated as follows: Meisner's point (23) = from Meisner's point (11, 12) to

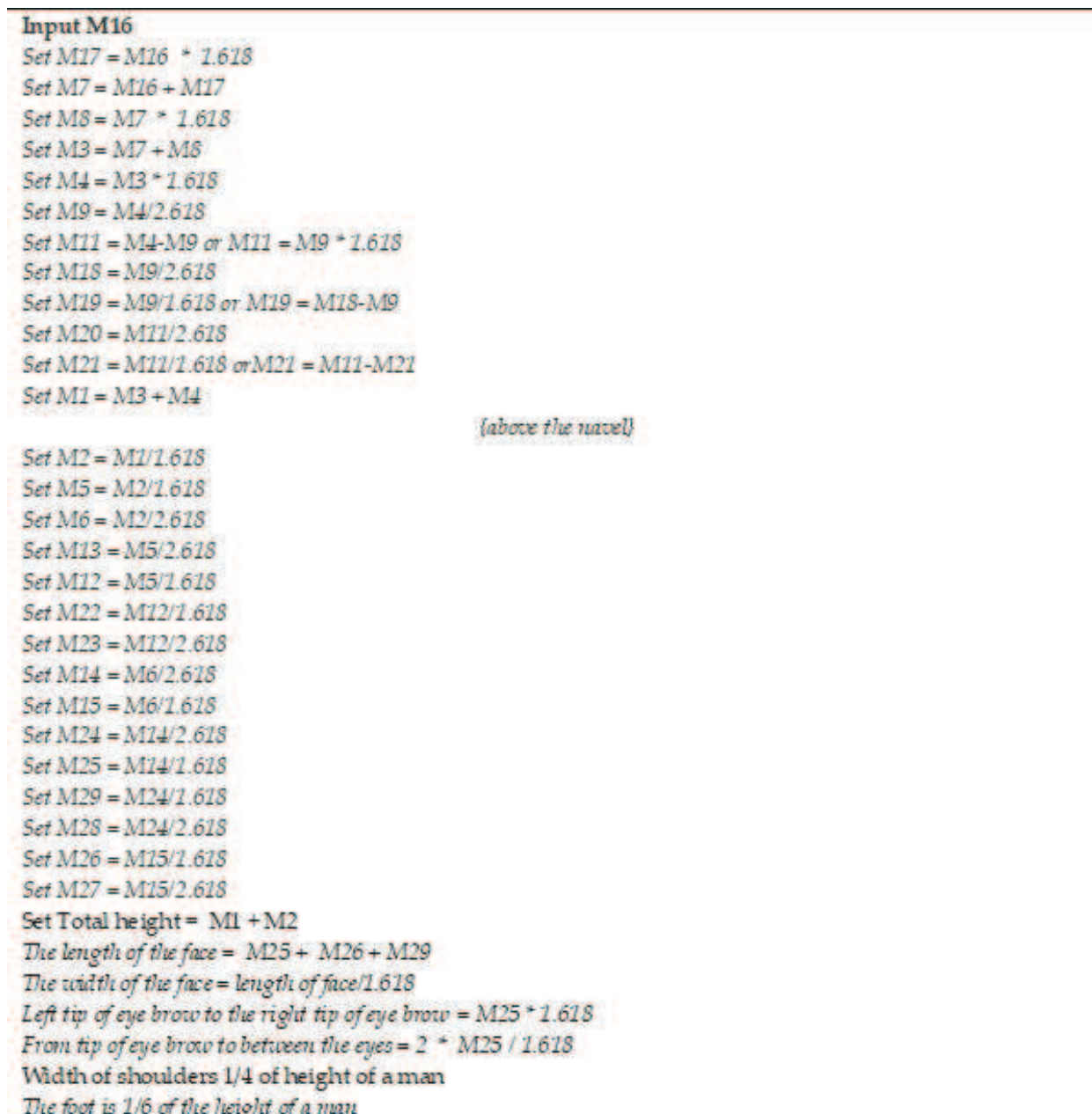

Figure 9. Human body measurements algorithm.

Meisner's point (33)/ (1 + 1.618) and Meisner's point (24) = from Meisner's point (11, 12) to Meisner's point (33)/ (1 + 1.618). Meisner's point (2) is calculated as follows: Meisner's point (2) = from Meisner's point (11, 12) to Meisner's point (33)/ (1 + 1.618), measuring from the top. To calculate Meisner's points (9, 10), the following must be done: Meisner's point (9) = difference from Meisner's point (3) to Meisner's point (19)/1.618 and Meisner's point (10) = difference from Meisner's point (4) to Meisner's point (20)/1.618. Meisner's point (17) = difference from Meisner's point (9) to Meisner's point (19)/1.618 and Meisner's point (18) = difference from Meisner's point (10) to Meisner's point (20)/1.618. Meisner's point (5) = difference from Meisner's point (3) to Meisner's point (7)/1.618 and Meisner's point (6) = difference from



Meisner's point (4) to Meisner's point (8)/1.618 from the top. Meisner's point (32) = the difference between Meisner's point (33) to Meisner's point (31)/1.618 from bottom. The Meisner's points (25, 26) can be calculated as follows: difference between (19,20) to (31)/1.618, hence calculate Meisner's point (25) = difference between (Meisner's point (18) and Meisner's point (31)/1.618 then Meisner's point (26) = difference between Meisner's point (20) to Meisner's point (31)/1.618.

The previous two paragraphs enhance the two algorithms suggested in **Figures 9** and **10** with more than 33 features that can be used in modeling a human face. The features are reflected as a continuum to the first algorithm in **Figure 11**.

<b>Input Total Height of a person (total)</b>
<i>Set M2 = total/2.618</i>
<i>Set M1 = total/1.618</i>
<i>Set M3 = M1/2.618</i>
<i>Set M4 = M1/1.618</i>
<i>Set M5 = M2/1.618</i>
<i>Set M6 = M2/2.618</i>
<i>Set M7 = M3/2.618</i>
<i>Set M8 = M3/1.618</i>
<i>Set M9 = M4/2.618</i>
<i>Set M11 = M4/1.618</i>
<i>Set M12 = M5/1.618</i>
<i>Set M13 = M5/2.618</i>
<i>Set M14 = M6/1.618</i>
<i>Set M15 = M6/2.618</i>
<i>Set M16 = M7/2.618</i>
<i>Set M17 = M7/1.618</i>
<i>Set M18 = M9/2.618</i>
<i>Set M19 = M9/1.618</i>
<i>Set M20 = M11/2.618</i>
<i>Set M21 = M11/1.618</i>
<i>Set M22 = M12/1.618</i>
<i>Set M23 = M12/2.618</i>
<i>Set M24 = M14/1.618</i>
<i>Set M25 = M14/2.618</i>
<i>Set M26 = M15/1.618</i>
<i>Set M27 = M15/2.618</i>
<i>Set M28 = M24/2.618</i>
<i>Set M29 = M24/1.618</i>
<i>The length of the face = M25 + M26 + M29</i>
<i>The width of the face = length of face/1.618</i>
<i>Left tip of eye brow to the right tip of eye brow = M25 * 1.618</i>
<i>From tip of eye brow to between the eyes = 2XM25/1.618</i>
<i>Width of shoulders 1/4 of height of a man</i>
<i>The foot is 1/6 of the height of a man</i>

**Figure 10.** Human body measurements algorithm.

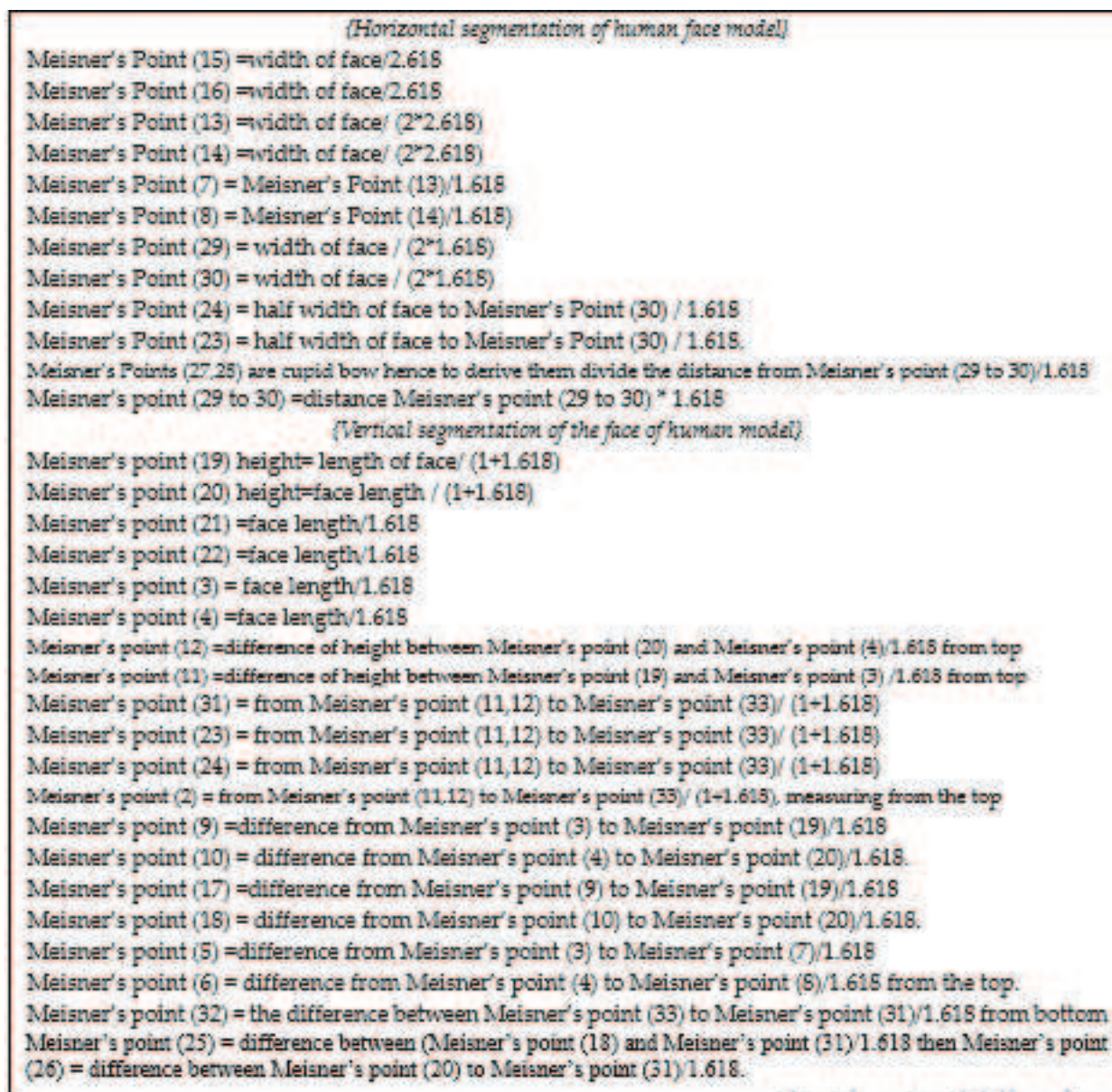

Figure 11. Human face segmentation a continuum from Figure 10.

The hand which is reflected as M20:M21 is 1:1.618, again M5 which is the elbow to tip of the shoulder, M5:M20 is 1:1.618. Hence when modeling a human figure, the following can be derived:

Length of hand name C: length of the arm (B) is proportion to 1:1.618.

Length of arm (B): length of elbow to tip of shoulder (A) is 1:1.618.

The fingers are proportional as follows: from tip of figure to distal phalange (C), from distal phalange to middle phalange is (B), and from middle phalange to proximal phalange is (A). The A:B: C of the whole arm is repeated in the figures proportions. The index finger from tip of

the figure to the first knuckles (distal phalange) is proportional to the second knuckle (middle phalange) 1:  $\varphi$ , which is equally similar to middle finger, ring finger, and little finger. The thumb from the tip to the (distal phalange) proportional to the proximal phalange is 1:  $\varphi$  and to the joint connecting the hand is 1:  $\varphi^2$  as shown in **Figure 10**.

## 7. Build a human body using golden ratio and suggested algorithm

This section presents two suggested algorithms that calculate all 35 measurements of the human model. The first algorithm shown in **Figure 9** where the input needed is the value of M16. The second algorithm also provides the model with 35 measurements according to golden ratio rules, with the input of the algorithm is the total height of the model. The author experimented with both algorithms and reflected the results in **Tables 2** and **3**. Furthermore, the results are shown on the model in **Figure 12**. The first suggested algorithm is explained next.

To build a human model according to the golden ratio using the rules explained above and suggested in **Figure 6** Bauentwurfslehre by Ernst Neufert, two algorithms are devised in **Figures 9** and **10** that would position the rules as shown next.

First, enter the one basic measurement which is M16 (the length from bottom of feet to ankle). Using the fact implied by formula (1) which is previously explained. Then M17 can be calculated by setting  $M17 = M16 \times 1.61803398874989$ . Once M17 is calculated, then M7 can be easily determined by using the previously explained formula (2). Furthermore, M8 can be calculated since such fact was established by formula (3).

Hence,  $M8 = M7 \times 1.61803398874989$  based on (3). Based on (4), M3 is  $M3 = M7 + M8$ . Based on (5),  $M19 = M18 \times 1.61803398874989$ . Based on (6),  $M9 = M18 + M19$ . Based on (7),  $M21 = M20 \times 1.61803398874989$ . According to (8)  $M11 = M20 + M21$ , and according to (9)  $M4 = M9 + M11$ , hence and using (10),  $M4 = M3 \times 1.61803398874989$ . Based on (11) M1 is  $M1 = M3 + M4$ , and based on (12)  $M1 = M2 \times 1.61803398874989$ . According to (13)  $M2 = M6 + M5$ , again apply (14)  $M2 = M5 \times 1.61803398874989$  and (15)  $M6 = M2/1.61803398874989$ . By using (17) and (18)  $M15 = M6 \times 1.61803398874989$ . Hence,  $M14 = M6/1.61803398874989$ ; according to (19)  $M5 = M12 + M13$ , further according to (20),  $M12 = M5/1.61803398874989$  and based on (21)  $M13 = M5/2.61803398874989$ . Based on (22),  $M12 = M23 + M22$  hence  $M22 = M12/1.61803398874989$  and based on (24),  $M23 = M12/2.61803398874989$ . Based on (25),  $M15 = M27 + M26$  hence based on (26),  $M26 = M15/1.61803398874989$  and based on (27),  $M27 = M15/2.61803398874989$ . According to (28) and the use of (29) and (30),  $M24 = M14/1.61803398874989$  and  $M25 = M14/2.61803398874989$ . Again, according to (31) and the use of (32) and (33),  $M29 = M24/1.61803398874989$  and  $M29 = M24 / 2.61803398874989$ .

Another version of the algorithm can be suggested when the total height is given, as illustrated in **Figure 10**. The author used a simple Microsoft Excel sheet to calculate the rest by applying the same rules seen in **Table 2**. In order to illustrate the process clearly, an example was set with original value of M16 = 6.13057 cm. To show the results of these simple calculations, the

M1: feet bottom to navel	110.0086
M2: navel to top of head	67.98906
M3: feet bottom to knee bottom line	42.01955
M4: knee bottom line to navel	67.98906
M5: navel to pit of throat and elbow to tip of the shoulder	42.01955
M6: pit of throat to top of head	25.96951
M7: bottom of feet to begin of calves	16.05004
M8: from calves to bottom line of knee	25.96951
M9: bottom line of knee to mid thighs (beginning of finger tips)	25.96951
M11: mid thighs (beginning of finger tips) to navel	42.01955
M12: navel to middle of chest	25.96951
M13: middle of chest to pit of throat	16.05004
M14: pit of throat to point between the eyes	16.05004
M15: point between the eyes to top of head	9.919471
<b>M16: bottom of foot to ankle</b>	6.13057
M17: ankle to beginning of calves	9.919471
M18: beginning of knees to end of knees	9.919471
M19: top of knees to tip of hand fingers	16.05004
M20: hand tip of fingers to hand rest	16.05004
M21: hand rest to elbow and navel to man gentiles	25.96951
M22: navel to beginning of chest (abdomen)	16.05004
M23: beginning of chest to middle of chest	9.919471
M24: throat pit to below nose	9.919471
M25: below nose to top of eyebrows	6.13057
M26: top of eyebrows to hair line	3.788901
M27: hair line to top of head	6.13057
M28: from throat pit to Adam's apple	3.788901
M29: Adam's apple to below the nose	6.13057
<i>The length of the face = M25 + M26 + M29</i>	15.9
<i>The width of the face = length of face/1.618</i>	9.826
<i>Left tip of eyebrow to the right tip of eyebrow = M25 × 1.618</i>	9.869
<i>From tip of eyebrow to between the eyes = 2 × M25/1.618</i>	7.5779
<i>Total height of a man = M1 + M2</i>	177.989
<i>Width of shoulders 1/4 of height of a man</i>	44.49725
<i>The foot is 1/6 of the height of a man</i>	29.666

**Table 2.** All M's calculated using Microsoft excel sheet.

Enter the height of a man in cm	178
1. The length of the outspread arms is equal to the height of a man	178
2. From the hairline to the bottom of the chin is 1/10 of the height of a man	17.8
3. From below the chin to the top of the head is 1/8 of the height of a man	22.25
4. From above the chest to the top of the head is 1/6 of the height of a man	29.66667
5. From above the chest to the hairline is 1/7 of the height of a man	25.42857
6. The maximum width of the shoulders is 1/4 of the height of a man	44.5
7. From the breasts to the top of the head is 1/4 of the height of a man	44.5
8. The distance from the elbow to the tip of the hand is 1/4 of the height of a man	44.5
9. The distance from the elbow to the armpit is 1/8 of the height of a man	22.25
10. The length of the hand is 1/10 of the height of a man	22.25
11. The root of the penis is at 1/2 the height of a man	89
12. The foot is 1/6 of the height of a man	29.666
13. From below the foot to below the knee is 1/4 of the height of a man	44.5
14. From below the knee to the root of the penis is 1/4 of the height of a man	44.5
15. The distances from the below the chin to the nose and the eyebrows and the hairline are equal to the ears and to 1/3 of the face	59.33333

Table 3. Proportions and heights as suggested by Vitruvian man model and reflect in Figure 12.

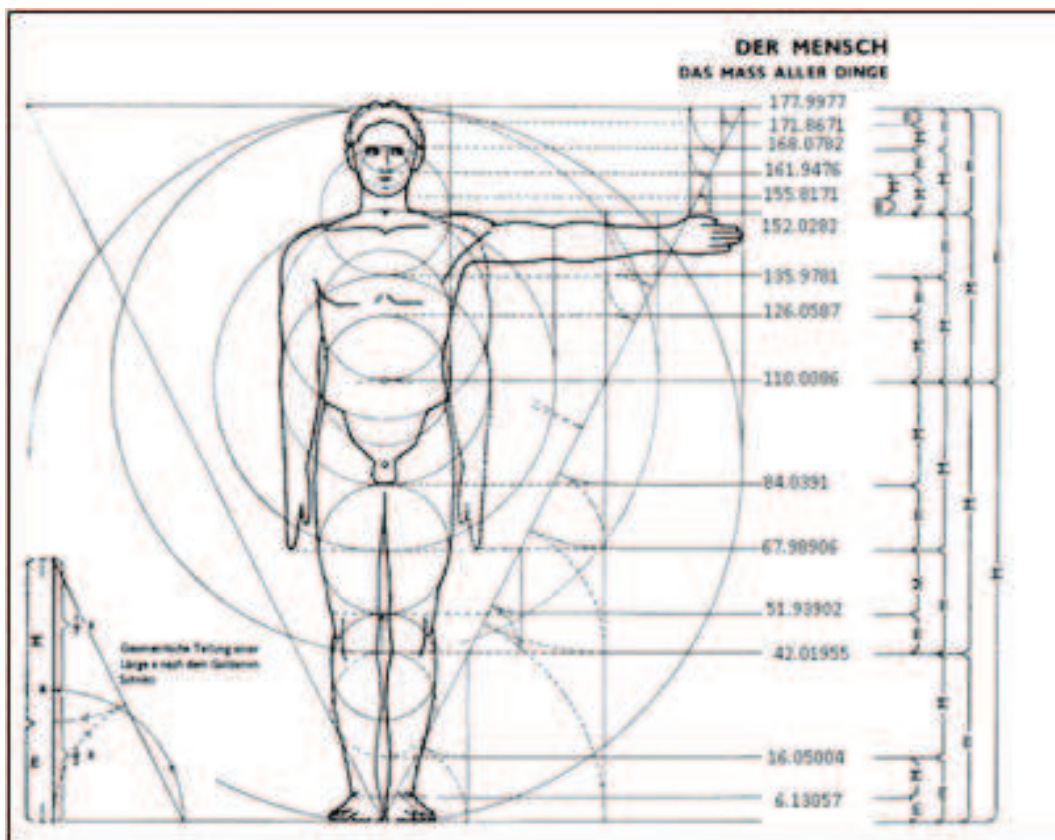

Figure 12. Bauentwurfslehre by Ernst Neufert [14] with heights reflected in centimeters with a base number M16 = 6.1305.

numbers were reflected on the same **Figure 10**, while it is worth noting that some interesting facts were realized and seen in **Table 2** as follows: first, M28 and M26 are equal to each other; second, M16, M25, M27, M29 are equal; and third, M15, M17, M18, M23, M24 are equal. Again, M7, M13, M14, M19, M20, M22 are all equal to each other. In addition, M21, M8, M9, M6, M12 are equal to M8 are equal to each other. And M3, M5, and M11 are equal to each other. Finally, M4 and M2 are equal to each other. Hence, the suggested algorithm can be done with minimum line of code as shown in **Figure 8**:

To build a human body using proportions suggested by Vitruvian Man discussed in the earlier section, then the height intended for the human figure should be designated first (shown in **Figure 12**). As illustrated by **Table 3**, the height entered was 178 cm, whereby using simple calculations, the results are shown in **Table 3**.

## 8. Conclusion

The goal of this chapter was to enable a multimedia modeler to model a human body using the golden ratio. Hence, the research uncovers 35 measures based on golden ratio introduced by *Bauentwurfslehre* by Ernst Neufert (1936) and Vitruvian Man (The Man in Action) by Leonardo da Vinci. The 67 measurements are: feet bottom to navel, navel to top of head, feet bottom to knee bottom line, knee bottom line to navel, navel to pit of throat & elbow to tip of the shoulder, pit of throat to top of head, bottom of feet to begin of calves, from calves to bottom line of knee, bottom line of knee to mid thighs (beginning of finger tips), mid thighs (beginning of finger tips) to navel, navel to middle of chest, middle of chest to pit of throat, pit of throat to point between the eyes, point between the eyes to top of head, bottom of foot to ankle, ankle to beginning of calves, beginning of knees to end of knees, top of knees to tip of hand fingers (hand toward earth), hand tip of fingers to hand rest, hand rest to elbow and navel to man gentiles, navel to beginning of chest (abdomen), beginning of chest to middle of chest, throat pit to below nose, blow nose to top of eyebrows, top of eyebrows to hair line, hair line to top of head, from throat pit to Adam's apple, Adam's apple to below the nose, the length of the face =  $M25 + M26 + M29$ , width of the face = length of face/1.618, left tip of eyebrow to the right tip of eyebrow =  $M25 \times 1.618$ , from tip of eyebrow to between the eyes =  $2 \times M25/1.618$ , width of shoulders 1/4 of height of a man, foot is 1/6 of the height of a man. The measurements are based on 25 proportional rules derived from 15 proportions given by Vitruvian Man and 29 golden proportions in *Bauentwurfslehre* by Ernst Neufert.

First, the chapter explained the golden section (mathematically, geometrically, arithmetically), then further demonstrated the golden ratio with phi. Furthermore, the chapter discussed Vitruvian Man (The Man in Action) by Leonardo da Vinci. Furthermore, explained *Bauentwurfslehre* by Ernst Neufert. The chapter, then, proposed how to build a human model using the ratios explained and proposed two algorithms that a modeler can follow to build a human body. The algorithms output can be used as proportions and an integral part of design and beauty of nature, to achieve beauty, balance, and harmony, thereby presenting visual parity serving guideline to human body modelers in simulation, gaming, plastic surgery, as well as the world of biometrics or wherever human body measurements and calculations is needed

like prosthetic limbs, spatial design, and machine learning of human biometrics. As such, the chapter facilitated and explained for the human modeler, the process of human modeling in multimedia arena. Hence, this research will be a spring board for researchers and practitioners in human modeling in multimedia field.

## Author details

Evon Abu-Taieh<sup>1\*</sup> and Hamed S. Al-Bdour<sup>2</sup>

\*Address all correspondence to: abutaieh@gmail.com

1 Information System Technology, The University of Jordan, Aqaba, Jordan

2 Information System Technology, The University of Jordan, Amman, Jordan

## References

- [1] Davis TA, Altevogt R. Golden mean of the human body. *Fibonacci Quarterly*. 1979;17:340-384
- [2] Dunlap A. *The Golden Ratio and Fibonacci Numbers*. Singapore: World Scientific Publishing; 1997
- [3] Euclid. *Elements*. 2012. Book 6, Definition 3. <http://aleph0.clarku.edu/~djoyce/java/elements/toc.html>. Retrieved May 1, 2012
- [4] Fett B. An in-depth investigation of the divine ratio. *The Montana Mathematics Enthusiast*. 2006;3(2):157-175
- [5] Golden ratio: The divine proportion. (n.d.) Beautiful proportion: <http://www.beautiful-proportion.com/2009/08/beautiful-proportions-golden-ratio-also.html>. Retrieved May 1, 2012
- [6] Lidwell W, Holden K, Butler J. *Universal Principles of Design: A Cross-Disciplinary Reference*. Gloucester: Rockport Publishers; 2003
- [7] Livio M. *The Golden Ratio: The Story of Phi, the World's most Astonishing Number*. New York: Broadway Books; 2002
- [8] Pacioli L. *Dedivina proportione*, Luca Paganinem de Paganinus de Brescia (Antonio Capella) (1509), Venice. [http://en.wikipedia.org/wiki/De\\_divina\\_proportione](http://en.wikipedia.org/wiki/De_divina_proportione). Retrieved May 1, 2012
- [9] Panero J, Zelnik M. *Human Dimension & Interior Space: A Source Book of Design Reference Standards*. New York: Watson-Guption Publications; 1979
- [10] Sadowski P. *The Knight on His Quest: Symbolic Patterns of Transition in Sir Gawain and the Green Knight*. Cranbury: Associated University Presses; 1996

- [11] Summerson J. *Heavenly Mansions: And Other Essays on Architecture*. New York: W.W Norton; 1963. p. 37
- [12] Taylor P. The Art of Bridging the Gap. From The New Zealand Herald. May 30, 2009. [http://www.nzherald.co.nz/auckland-region/news/article.cfm?l\\_id = 117&objectid = 10575355](http://www.nzherald.co.nz/auckland-region/news/article.cfm?l_id = 117&objectid = 10575355). Retrieved May 1, 2012
- [13] Wolfram. Golden Ratio, Mathworld (n.d.): <http://mathworld.wolfram.com/GoldenRatio.html> 9/
- [14] Word Press Files. Retrieved December 28, 2011. <http://thefunambulistdotnet.files.wordpress.com/2012/04/nnj-abb5.gif>
- [15] Hambidge J. *Dynamic Symmetry: The Greek Vase*. New Haven: Yale University Press; 1920
- [16] Abu-Taieh E. An algorithm for human modeling in information technology multimedia using human biometrics found in golden ratio, vitruvian man and neufert. In: 2015 Fifth International Conference on e-Learning (ECONF); 2015; Manama, pp. 65–73. DOI: 10.1109/ECONF.2015.43.<http://ieeexplore.ieee.org/stamp/stamp.jsp?tp=&arnumber=7478214&isnumber=7478193>
- [17] Abu-Taieh E, El-Maheed M, El-Maheed M, Abu-Tayeh A, Abu-Tayeh J, El-Haj A. Human modeling in information technology multimedia using human biometrics found in golden ratio, Vitruvian man and Neufert. In: *Proceedings IBIMA Conference: Innovation Vision 2020*, Spain. 2012. pp. 858–869
- [18] Golden ratio in art composition and design, Gary Meisner. 2014. <https://www.goldennumber.net/art-composition-design/>. Retrieved January 25, 2018
- [19] Gary Meisner. Meisner beauty guide for golden ratio facial analysis. March 21, 2016. <https://www.goldennumber.net/meisner-beauty-guide-golden-ratio-facial-analysis/>
- [20] Neufert E. *Architects' Data*. Blackwell Science. 1936. [http://www.vgloop.com/\\_files/1403617229-311131.pdf](http://www.vgloop.com/_files/1403617229-311131.pdf)
- [21] Markowsky, George. Misconceptions about the golden ratio. *College Mathematics Journal*. January 1992;23(1):2-19



