

We are IntechOpen, the world's leading publisher of Open Access books Built by scientists, for scientists

4,500

Open access books available

118,000

International authors and editors

130M

Downloads

Our authors are among the

154

Countries delivered to

TOP 1%

most cited scientists

12.2%

Contributors from top 500 universities



WEB OF SCIENCE™

Selection of our books indexed in the Book Citation Index
in Web of Science™ Core Collection (BKCI)

Interested in publishing with us?
Contact book.department@intechopen.com

Numbers displayed above are based on latest data collected.
For more information visit www.intechopen.com



Review on UWB Bandpass Filters

Li-Tian Wang, Yang Xiong and Ming He

Abstract

Rapid development of a number of wireless communication systems imposed an urgent requirement for a technology which contains multi-wireless communication standard. Since the ultra-wideband (UWB) technologies are of advantage in broad bandwidth and high-speed transmission, much attention has been paid to exploiting the UWB bandpass filters. In this chapter, the development process of the UWB bandpass filters and the regulation of the UWB bandpass filter are initially introduced. Subsequently, the application scenarios of UWB filters in UWB communication systems and unique merits of UWB filters were explored. In addition, the primary performance specifications of the UWB filters, including insertion loss, return loss, the level of out-of-band attenuation, and roll-off rate, are also presented. After a brief discussion of microwave network theory, several methods for implementing UWB filters are summarized. Furthermore, the design of the UWB filter with notch band is presented in Section 5. The last section, the Conclusion section, is given at the end of this chapter.

Keywords: UWB bandpass filter, multimode resonator, step-impedance resonator, wide stopband, high selectivity, notch band

1. Introduction

The ultra-wideband (UWB) communication technology with a long history is developed rapidly in the past few decades. Since 1989, the UWB was first employed by the Defense Advanced Research Projects Agency (DAPRA) as a term, and the DAPRA also proposed the bandwidth definition of the UWB. In fact, the UWB technology was only authorized to be applied in military communications. Since February 2002, the development of UWB has undergone a great change. The Federal Communications Commission (FCC) finally released the UWB spectrum globally for data communication or radar and security field for civilian application and redefined the bandwidth of UWB, which specifies that the UWB radio-frequency signal has a fractional bandwidth (FBW) greater than 20% or 10 dB absolute bandwidth greater than 500 MHz. According to the definition of FCC part 15 [1], the authorized band allocated to the UWB communication systems is ranging from 3.1 to 10.6 GHz. Unprecedented 7.5 GHz of bandwidth is the largest bandwidth of any commercial terrestrial system has ever allocated. The 3 dB FBW of the UWB can reach 109%, and FCC emission mask specified that the transmission power does not exceed -41.3 dBm/MHz (75 nW/MHz). The way of sharing the spectrum with extremely low-power spectral densities (PSD) is of paramount significance in present intense crowded spectrum circumstance. The major merits of the UWB are as follows:

Firstly, high data rate: according to the Shannon formula for channel capacity [2], the maximum information data rate of the system in the additive white Gaussian noise (AWGN) channel can be expressed as

$$C = B \log_2 \left(1 + \frac{S}{N} \right) \quad (1)$$

where B stands for channel width and S/N denotes the signal-to-noise ratio. Hence, it can be concluded from Eq. (1) that even if the signal-to-noise ratio values are as low as 0.1 (−10 dB), the system's data rate still can reach as high as 1 Gbps. It fully demonstrates the extremely high data rate of the UWB system. Secondly, strong anti-interference ability: UWB resorts to carrierless communication with nanosecond pulses. With Fourier transform, it can be derived that the power spectral density is dramatically wide with low-energy density, which reveals that the UWB system is of excellent concealment. Thirdly, high resolution ratio of time and space: the UWB is operating at high frequency with a nanosecond resolution of time domain, and the short wavelength at the RF enables spatial resolution of 0.1 m approximately. The rapid development of 5G [3] and the Internet of Things (IoT) [4] has an urgent demand for high response speed and high positioning accuracy, and the UWB can perfectly meet this requirement. The emergence of key reports and research process, whether from an academic or engineering perspective, has greatly advanced the development of UWB over the past few decades.

The UWB bandpass filters served as key building block in UWB wireless communication systems to regulate the FCC UWB masks have aroused much research interest in this century. And various attempts to design UWB have been reported continuously. The UWB bandpass with a FBW of more than 20% have been reported with simple design methodology and excellent passband performance since 2012 [5, 6]. However, for the FCC authorized specification, 109% of the FBW is actually an unprecedented challenge in approaching UWB bandpass filters design. Despite the well-established comprehensive design theory for narrowband bandpass filters with varied specification [7–10], the synthesis design methods for UWB bandpass filters are not suitable to employ existing powerful design theory foundations.

Various techniques have been presented to develop the UWB bandpass filters. One of the straightforward methods is cascading a low-pass filter and a high-pass filter to accomplish UWB bandpass filter [11–13]. Though considerable wideband is realized in [11], the occupied circuit size needs to be further reduced. To achieve UWB bandpass filters with compact size and simple design process, multimode resonator (MMR) has been presented [14–25]. In [16], the UWB bandpass filter is achieved with wide stopband, and 40 dB attenuation can be realized within frequency ranging from 12.0 to 16.0 GHz. In [19], quintuple-mode resonator is introduced to design UWB bandpass filter and sharp skirt, and wide upper stopband is achieved simultaneously. A UWB bandpass filter with 20 dB out-of-band suppression up to 25.1 GHz is proposed in [21]. In [25], a novel MMR with interdigital-coupled-microstrip line sections is implemented, which can excite seven transmission poles to design UWB bandpass filter with high roll-off rate. In summary, design of UWB bandpass filters by using MMR is of compact size and with multi-transmission poles, whereas the range of out-of-band rejection is still insufficient since harmonic effects. Similar to the MMR, the stub-loaded multimode resonator (SLMMR) is another ideal structure to design UWB bandpass filters owing to its simple structure and easy design procedure [26–33]. In [26], a highly selective UWB bandpass filter is achieved by short-circuit stub-loaded structure, which can excite 11 resonant modes to fulfill the requirement of UWB with miniature circuit size.

The stub-loaded quintuple-mode resonator is employed to design UWB bandpass filter with two transmission zeros near the lower and the upper cutoff frequencies in [30]. To address the issue of harmonic effect to obtain wide stopband, the step-impedance resonator (SIR) is utilized to design UWB bandpass filters with removed harmonic [33–37]. A UWB bandpass filter with more than 30 GHz out-of-band attenuation is approached by using SIR in [34]. The novel ring resonators are considered as an effective way to design UWB bandpass filters attributed to its miniature size and multiple resonance behavior [38–46]. In [39], a design of UWB bandpass filter with extremely compact circuit size (0.46 cm^2 , without feedlines) by using quintuple ring resonator is proposed. In [42], UWB with switchable bandwidth is also investigated by implementing a ring resonator, and tunable passband ratio of 1.22:1.13:1 is obtained. Another major category of UWB bandpass with desired UWB passband performance is based on the parallel-coupled lines [47, 48]. In [48], by using parallel-coupled microstrip lines, a UWB bandpass filter with a passband from 3.1 to 10.6 GHz of less than 1 dB insertion loss is accomplished; meanwhile, the attenuation level can reach 40 dB in stopband. In order to cater for the urge demand for miniaturization, UWB bandpass filters with multilayer structures have been extensively investigated and reported [49–58]. In [57], design of an eight-pole UWB filter is demonstrated; meanwhile the proposed UWB filter not only has merits of miniature circuit size but also processes a 38.1 dB out-of-band suppression by utilizing the multilayer structure. In addition to the aforementioned techniques, there were also other routines to obtain the UWB bandpass filter, such as semi-lumped UWB bandpass filter [58, 59] and UWB bandpass filter designed with right-/left-banded structure [60–62]. Furthermore, for the purpose of achieving the UWB communication while eliminating other inferences of current communication systems, notch band UWB bandpass filter is presented [60, 63–77] and will be demonstrated in detail in Section 6 of this chapter.

This chapter mainly focuses on the various approaches to achieve UWB bandpass filter and the discussion of several conventional methods for high-performance UWB filter with wide stopband, high out-of-band attenuation, sharp selectivity, and miniaturization. Therefore, the organization of this chapter is as follows: in Section 2, application scenarios of UWB, development history of UWB, and the UWB regulations established by the FCC are briefly demonstrated. In Section 3, the major specifications of the UWB filters as well as the foundation of design methodology are illustrated. Section 4, the key section, focuses on varied approaches to realize the UWB filter design. Common ways for accomplishing the design of UWB filters can be classified into the following categories: one of the general methods of designing UWB bandpass filter is using multimode resonator (MMR) (Section 4.1), and similar to the method in Section 4.1, UWB bandpass filters are also realized by using a stub-loaded multimode resonator (SLMMR) (Section 4.2). The methods of implementing the UWB bandpass filter with multilayer structure, parallel-coupled line, and step-impedance resonator design methodology are, respectively, reviewed in Sections 4.3–4.5. In order to fulfill the requirement to eliminate the RF interference within the UWB band, the UWB bandpass filter with notch band has been designed and reported extensively, which is reviewed in Section 5. Section 6, the Conclusion section, will be given at the end of this chapter.

2. Regulation and application

The UWB wireless communication has been only authorized to the military communication for 42 years. Since 2002, the FCC released the unlicensed

employment of UWB for commercial purpose and classified the application scenario into imaging system, vehicle radar system, and communication and measurement system. According to the regulation of FCC, the f_L and f_H are located at 3.1 and 10.6 GHz, where f_L and f_H , respectively, stand for the frequencies with 10 dB attenuation of the upper and lower sidebands. Therefore, the center frequency of UWB bandpass filter is expressed as

$$f_c = \frac{f_H + f_L}{2} = 6.85 \text{ GHz} \quad (2)$$

Meanwhile, the *FBW* can also derived as

$$FBW = \frac{2(f_H - f_L)}{f_H + f_L} = 109.5\% \quad (3)$$

For the purpose of evading the interference of UWB systems and existing communication systems (such as GPRS, WLAN, TD-LTE, and mobile cellular), the radiation spectral density of UWB systems is strictly limited and regulated, the highest power spectral density of the UWB systems regulated not exceeding -41.3 dBm/MHz, as illustrated in **Figure 1**. It is worth noting that the regulation also varies depending on the indoor and outdoor circumstance.

As depicted in **Figure 2**, the UWB band has an extremely high *FBW* and unparalleled 7.5 GHz absolute bandwidth; the UWB therefore has potential in many applications. The UWB can be applied to support large channel capacity since its huge bandwidth, whereas its propagation distance is limited by low effective isotropic radiated power (EIRP). Therefore, the UWB is an ideal candidate for short-distance high-rate communication. For detecting, the UWB has a dramatic penetrating ability by using its outstanding weak narrow pulse of baseband, which can easily penetrate the leaves, the earth's surface, the clouds, and the concrete; even objects behind the obstacle can also detected. For locating, high positioning accuracy can be accomplished by UWB technology, whether for military or civilian application.

The UWB bandpass filters have the responsibility to remove the unwanted signals and noise in UWB communication system. As shown in **Figure 3**, for the transmitting system, the modulated signal is directly filtered by using the UWB bandpass filter, and the UWB bandpass filter is also a critical component in RF front

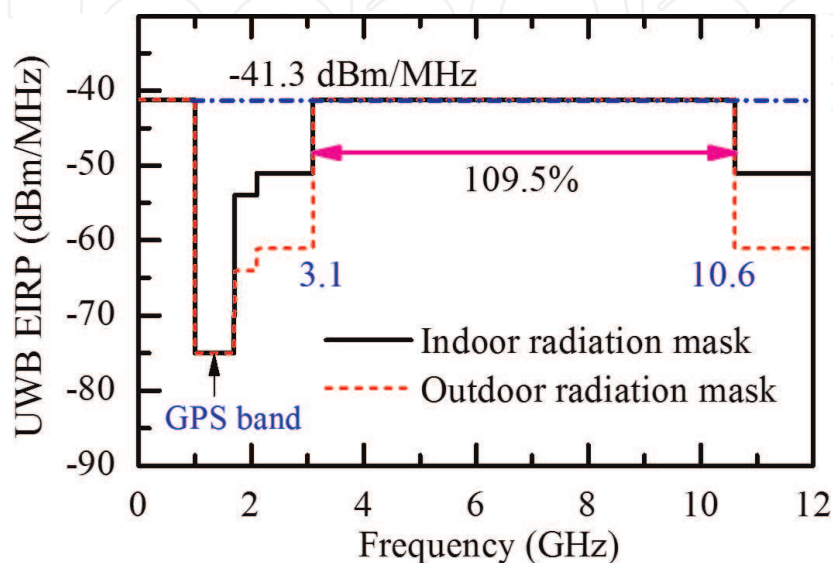

Figure 1.
Indoor radiation masks and outdoor radiation mask regulated for UWB system by FCC.

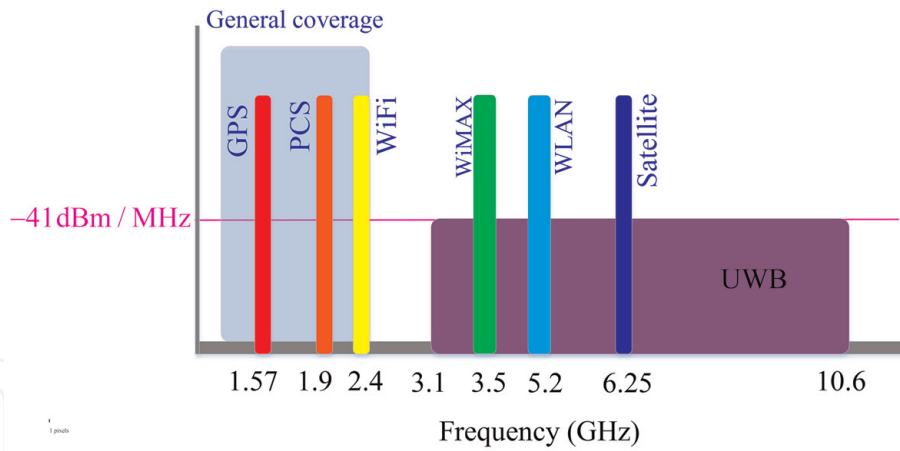

Figure 2.
 The comparison between the UWB spectrum and spectrum of currently commercial communication systems.

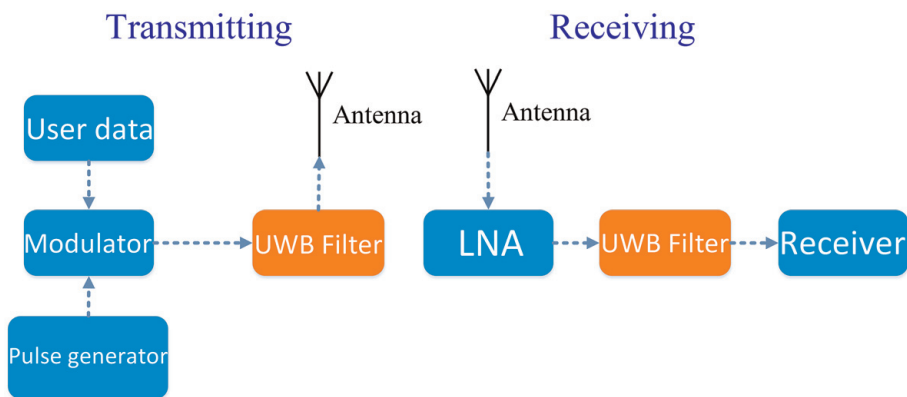

Figure 3.
 The sketch of transmitting system and receiving system with primary components.

end of the receiving system [5]. Therefore the UWB bandpass filters are known as an inevitable key building block of wideband communication systems, and the filtering performance of UWB bandpass filter will directly related to the performance of the entire UWB system.

3. Microwave foundation of designing UWB bandpass filters

3.1 Performance specifications

The performance is a critical factor for UWB filters even in any engineering device, and the major parameters for UWB filter performance evaluating are as follows:

1. Insertion loss (*IL*): insertion loss is the attenuation caused by the introduction of the device between the in port and out port, usually expressed in dB. The insertion loss can be calculated as follows:

$$IL = 10 \log \frac{P_{in}}{P_{out}} \text{ (dB)} \quad (4)$$

where P_{in} is the input transmitted power and the P_{out} is the output received power. In addition to the mismatching loss, the actual bandpass filters have a series of other losses. Firstly, dielectric loss, can expressed as

$$\alpha'_d = 27.3 \frac{\tan \delta}{\lambda_g} \text{ dB/cm} \quad (5)$$

where the λ_g is the guide wavelength of 50 Ω microstrip line at frequency f . Secondly, the conductor loss, can be derived from

$$\alpha_a = \frac{\sqrt{\pi f \mu_0 \sigma}}{4(w + t)\sigma \cdot Z_0} \quad (6)$$

where μ_0 is the permeability of vacuum, σ is the conductivity, w is the width of conductor, and t is the conductor thickness.

Thirdly, the dielectric loss, can be written as

$$\alpha_d = \tan \delta \cdot \pi / \lambda_g \quad (7)$$

2. Return loss (RL): return loss is the ratio of the reflected power to the incident wave power, expressed in dB:

$$RL = 10 \log \frac{P_{re}}{P_{in}} \text{ (dB)} \quad (8)$$

3. FBW and center frequency

4. Roll-off rate (ROR): the ROR is a critical specification for evaluating passband selectivity and can be defined as follows:

$$ROR = \frac{|\delta_{-20dB} - \delta_{-3dB}|}{|f_{-20dB} - f_{-3dB}|} \quad (9)$$

where $\delta_{-20 \text{ dB}}$ and $\delta_{-3 \text{ dB}}$ are attenuation point at -20 and -3 dB, respectively. $f_{-20 \text{ dB}}$ and $f_{-3 \text{ dB}}$ are, respectively, -20 and -3 dB stopband frequency.

5. Group delay: the ratio of phase variation to frequency variation is utilized to describe the overall delay of signal though the device. The group delay can be derive as

$$\tau = -\frac{\partial \varphi_{21}(\omega)}{\partial \omega} \quad (10)$$

6. Out-of-band suppression level: the stopband suppression level is applied to evaluate the out-of-band performance of the UWB bandpass filter.

7. Upper stopband bandwidth: it is worth noting that there is no spike in the stop band.

8. Transmission poles: multi-transmission poles prone to achieve UWB bandpass filters with sharp skirt.

9. Transmission zeros: the UWB bandpass filter with multi-transmission zeros tends to process excellent out-of-band rejection and high selectivity of passband.

3.2 Foundation of conventional transmission line filter analysis

The critical step in the design of a conventional transmission line UWB filter is to select the appropriate electrical lengths/impedances of transmission lines to

adjust the resonant modes to fulfill the design specifications of UWB bandpass filter. For the purpose of establishing the expression of the resonant frequencies and each electrical lengths or impedances, the Y_{in} of UWB filter needs to be derived, and the resonance condition can be calculated by using the following expression:

$$\text{Im}(Y_{in}) = 0 \quad (11)$$

As demonstrated in **Figure 4**, the detailed steps for solving resonant frequencies with numerical calculation are as follows:

Step 1, Initialization. The electrical lengths θ_i ($i = 1, 2, \dots, n$), f_0 (reference frequency for electrical length calculation), and frequency sweep range should be given.

Step 2, Recalculating the electrical lengths. When the frequency f_i is considered, all of the electrical lengths should be recalculated as $\theta_n' = \theta_n f_i / f_0$. Then, we substitute the updated electrical lengths into Eqs. (2)–(8).

Step 3, if Eq. (1) is satisfied, that is, $f_1 = f_i$ is the first resonant frequency that we are searching for, then the resonant frequency f_1 should be saved and turn to the next step. If Eq. (1) is not satisfied, the program turns to the next step directly.

Step 4, considering the next frequency f_{i++} .

Step 5, is the new value of f_{i++} beyond the frequency sweep range? If the answer is yes, then quit and end the program. If the answer is no, then go to step 2.

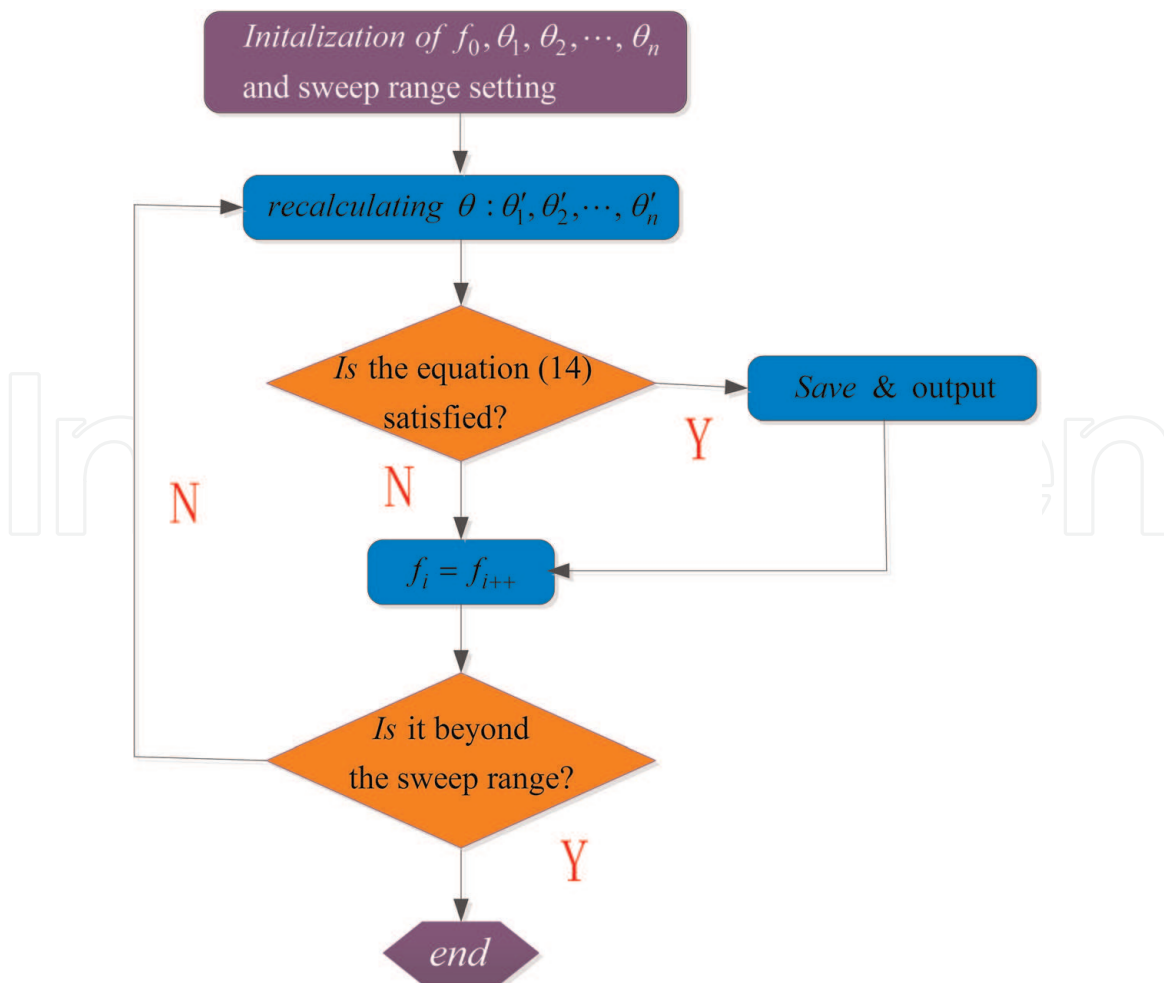

Figure 4. Flow chart of solving the resonant frequency.

3.2.1 Classical even-odd-mode analysis method

Since the odd-mode resonant frequencies of the symmetrical structure are orthogonal to the even-mode resonant frequencies, the whole transmission line model can be divided into odd-mode and even-mode circuits. Therefore, the resonant frequencies are then derived separately, which dramatically reduces the computation of resonant modes. It is worth noting that with odd-mode excitation, the symmetrical planes are considered to be grounded and with even-mode excitation, the symmetrical planes are considered to be open.

Even-/odd-mode input admittance can be obtained from the even-/odd-mode equivalent circuit, and Eq. (11) can be replaced by the following equations:

$$\text{Im}(Y_{\text{ine}}) = 0 \quad (12)$$

$$\text{Im}(Y_{\text{ino}}) = 0 \quad (13)$$

3.2.2 Classical [ABCD] matrix analysis method

The analysis of traditional transmission line filters with asymmetric structures is no longer within the application scope of classical odd-even-mode analysis method. To overcome this issue, the ABCD matrix method is employed to approach the overall transmission ABCD matrix; the Y_{in} is then derived from the ABCD matrix of the overall structure. The ABCD matrix of several typical transmission line models and the ABCD matrix of several conventional circuit elements are depicted in **Figure 5**.

3.2.3 Analysis of parallel-coupled lines

The analysis of parallel-coupled lines is more complicated than that of series/shunt transmission lines. One of the reliable ways is to analyze the parallel-coupled lines as a four-port component, and parameters of parallel-coupled lines are shown in **Figure 6**.

Different paralleled coupling conditions and the position of the in/out port correspond to varied initial conditions. Therefore, the Z matrix of parallel-coupled lines can be solved according to this initial condition. The four-port impedance matrix is given as follows.

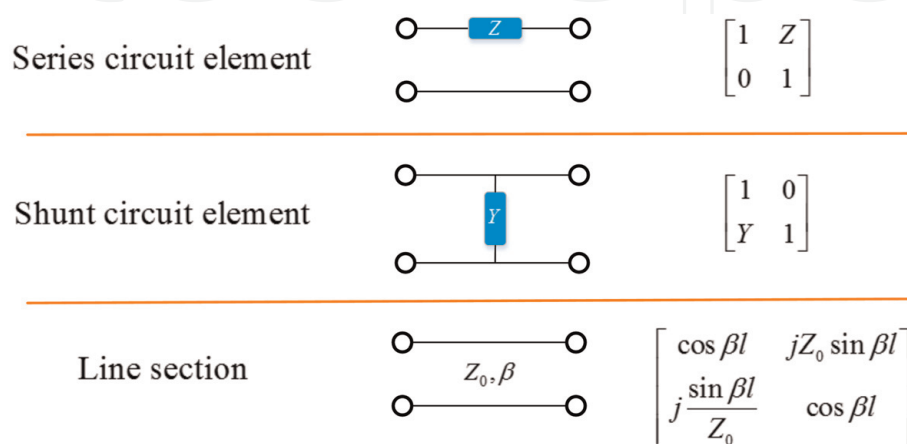

Figure 5. Classical transmission line structure and their ABCD matrix.

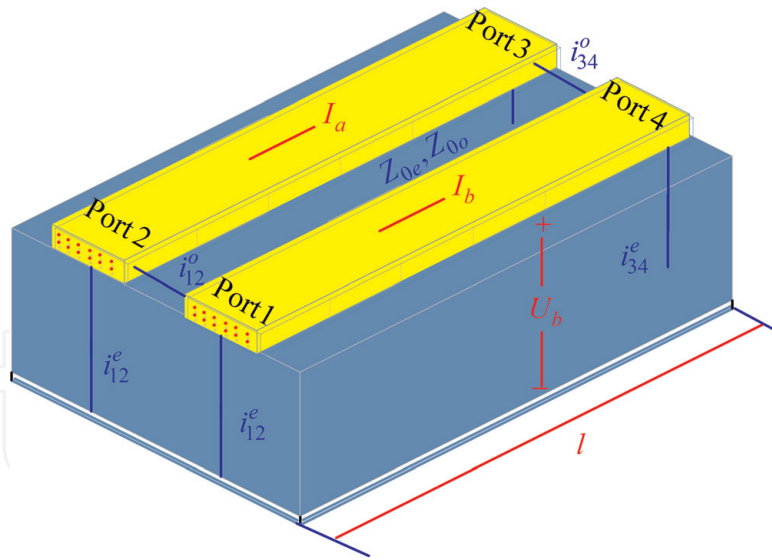

Figure 6.
 Electrical diagram of parallel-coupled line.

$$\begin{bmatrix} U_1 \\ U_2 \\ U_3 \\ U_4 \end{bmatrix} = \begin{bmatrix} Z_{11} & Z_{12} & Z_{13} & Z_{14} \\ Z_{21} & Z_{22} & Z_{23} & Z_{24} \\ Z_{31} & Z_{32} & Z_{33} & Z_{34} \\ Z_{41} & Z_{42} & Z_{43} & Z_{44} \end{bmatrix} \begin{bmatrix} I_1 \\ I_2 \\ I_3 \\ I_4 \end{bmatrix} \quad (14)$$

where

$$Z_{11} = Z_{22} = Z_{33} = Z_{44} = -j \frac{Z_{0e} + Z_{0o}}{2} \cot \theta \quad (15)$$

$$Z_{12} = Z_{21} = Z_{34} = Z_{43} = -j \frac{Z_{0e} - Z_{0o}}{2} \cot \theta \quad (16)$$

$$Z_{13} = Z_{31} = Z_{24} = Z_{42} = -j \frac{Z_{0e} - Z_{0o}}{2} \csc \theta \quad (17)$$

$$Z_{14} = Z_{41} = Z_{23} = Z_{32} = -j \frac{Z_{0e} + Z_{0o}}{2} \csc \theta \quad (18)$$

4. Common UWB bandpass filters

4.1 UWB bandpass filters using MMR

A quintuple-mode resonator is proposed to design UWB bandpass filter, and the physical layout of the presented UWB filter is sketched in **Figure 7** [19]. Since the whole structure is symmetrical along the $T-T'$ line, classical odd-even-mode method is adopted to analyze the quintuple-mode resonator. As demonstrated in **Figure 8**, five resonant modes can be generated by quintuple-mode resonator; besides, owing to the loaded stub, two transmission zeros are realized both at lower and upper cutoff frequencies; thus, high selectivity is approached. As shown in **Figure 9**, the measurement results are in good agreement which shows sharp skirt and ultra-wide stopband of the UWB bandpass filter (**Figure 9**).

4.2 UWB bandpass filters using SLMMR

As illustrated in **Figure 10**, dual short stub-loaded resonator is presented to construct UWB transmission characteristics [31]. Owing to symmetrical structure

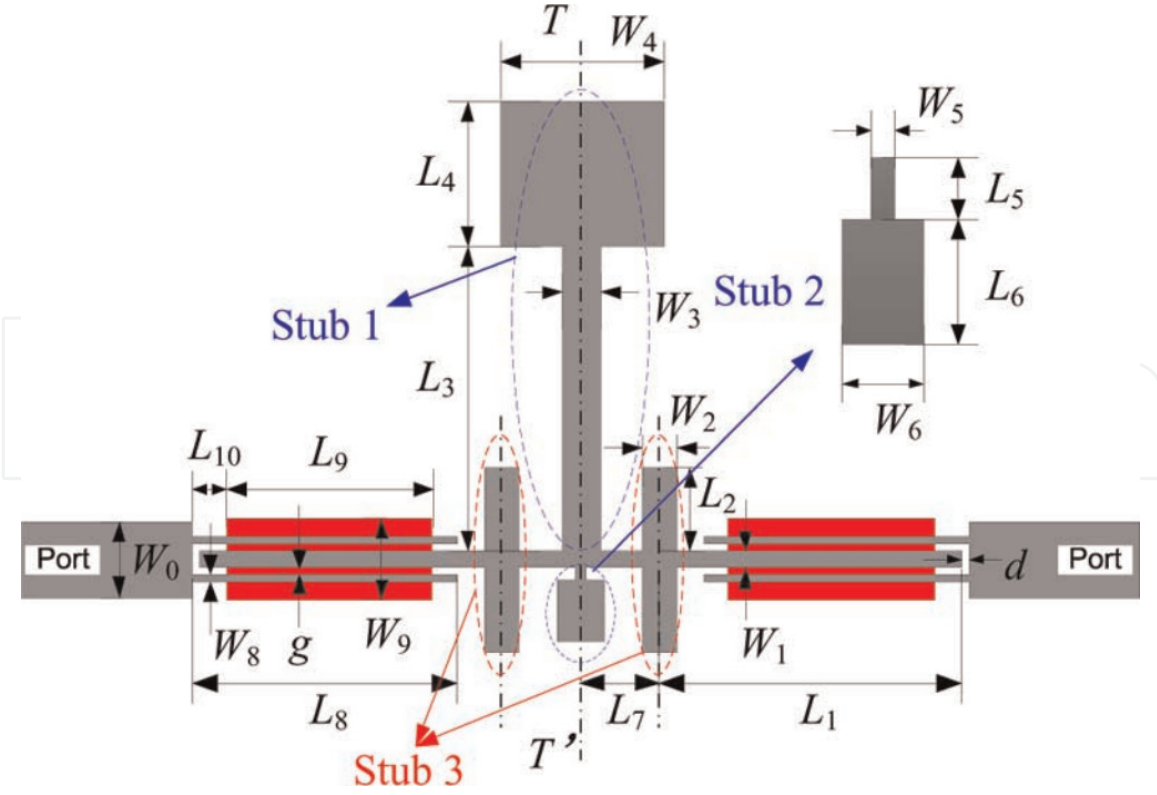

Figure 7.
Physical layout of the quintuple-mode resonator.

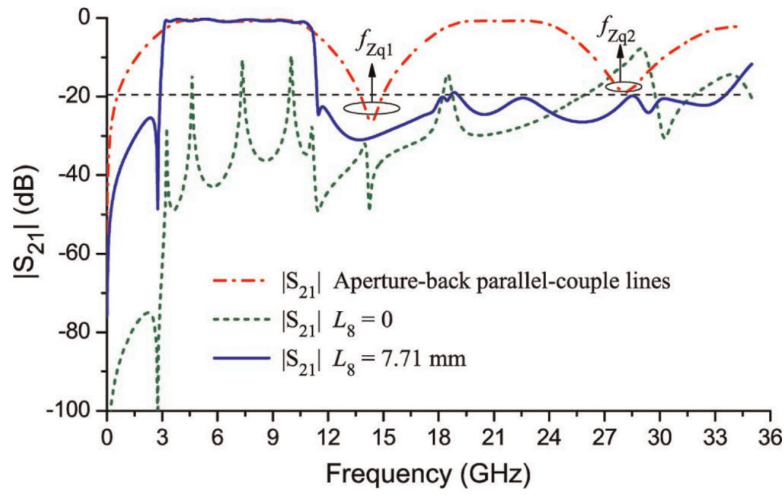

Figure 8.
Transmission coefficient $|S_{21}|$ versus weak coupling and strong coupling.

of the presented SLMR, classical odd-even-mode method can be introduced to analyze the resonant modes of UWB filter. With even-mode excitation and odd-mode excitation, the input admittance can be, respectively, written as follows:

$$Y_{ine} = Y_c \frac{(jY_1 \tan \theta_1 - jY_2 \cot \theta_2 + jY_3 \tan \theta_3) + jY_c \tan \theta_c}{Y_c + (-Y_1 \tan \theta_1 + Y_2 \cot \theta_2 - Y_3 \tan \theta_3) \tan \theta_c} \quad (19)$$

$$Y_{ino} = Y_c \frac{(-jY_1 \cot \theta_1 - jY_2 \cot \theta_2 + jY_3 \tan \theta_3) + jY_c \tan \theta_c}{Y_c + (Y_1 \cot \theta_1 + Y_2 \cot \theta_2 - jY_3 \tan \theta_3) \tan \theta_c} \quad (20)$$

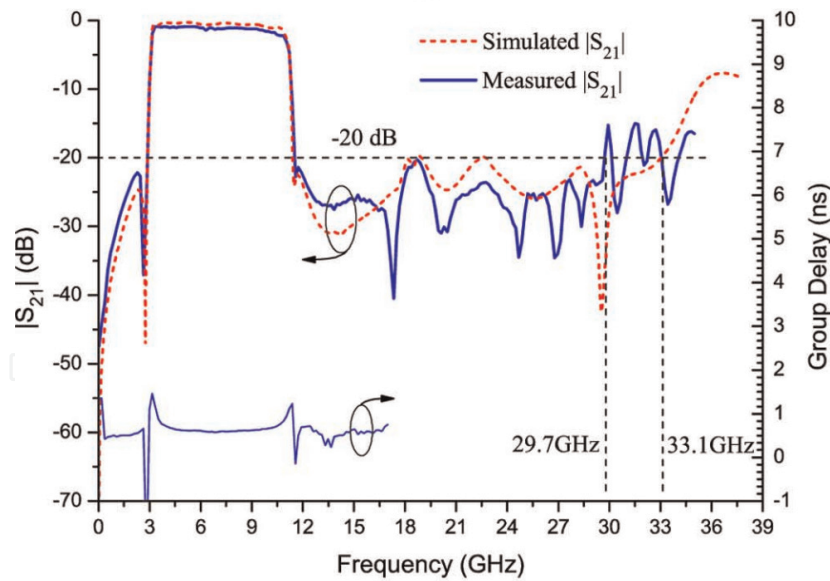

Figure 9.
 Simulated and measurement frequency responses of presented UWB.

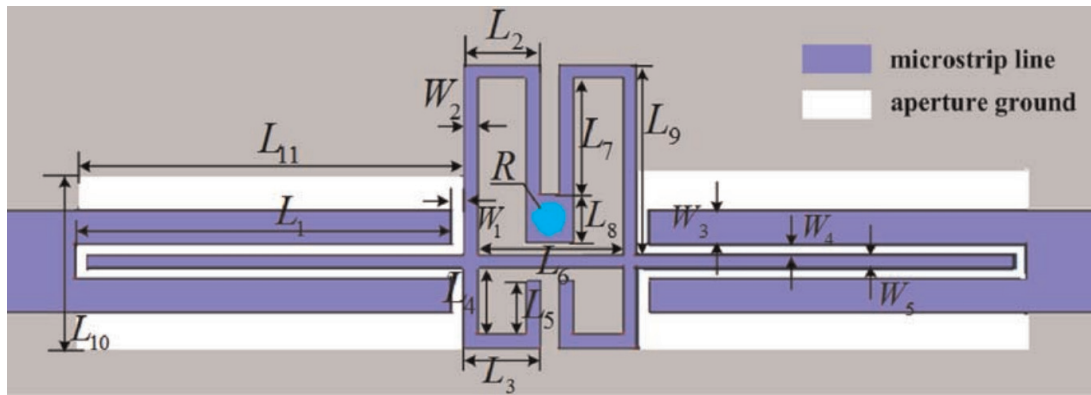

Figure 10.
 Schematic diagram of proposed UWB bandpass filter with SLMMR.

By using the numerical calculation method mentioned in **Figure 4**, the design graphs for implementing UWB bandpass filter are sketched in **Figure 11**. For example, by properly choosing the values of θ_2 , the excited four resonant frequencies can be easily adjusted to the desired UWB specifications. Therefore, the first four resonant modes are located at 2.86, 5.58, 8.56, and 10.21 GHz, and the dimension parameters are optimized by IE3D as follows: $L_1 = 8$, $L_2 = 1.6$, $L_3 = 1.6$, $L_4 = 1.4$, $L_5 = 1.2$, $L_6 = 3$, $L_7 = 2.5$, $L_8 = 1$, $L_9 = 4$, $L_{10} = 3.6$, $L_{11} = 8$, $W_1 = 0.2$, $W_2 = 0.3$, $W_3 = 0.6$, $W_4 = 0.2$, and $W_5 = 0.3$. It can be observed in **Figure 12** that simulation results are in good agreement with measurement results, which shows UWB bandpass characteristics with small and flat group delay in the passband.

4.3 UWB bandpass filters with multilayer structure

In order to design bandpass filter with UWB performance while occupied compact size, dual-layered structure is proposed in [56]. The UWB filter is constructed by substrate integrate waveguide (SIW) ridge resonator, and the bandwidth of the UWB filter can be easily tuned by properly changing the width of rod in ridge resonator. The scheme diagram is sketched in **Figure 13**.

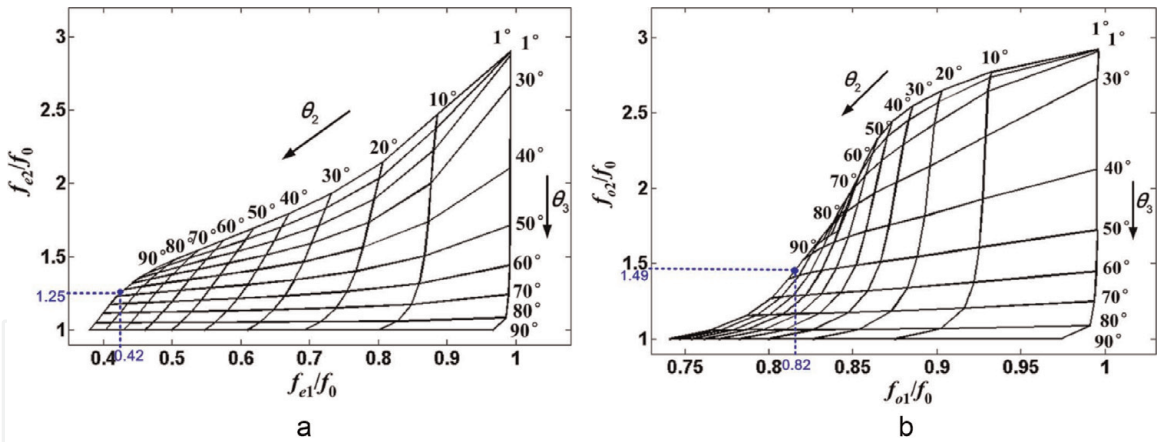

Figure 11. Design graph for SLMMR, (a) normalized even-mode resonance frequencies versus θ_2 , (b) normalized odd-mode resonance frequencies versus θ_2 .

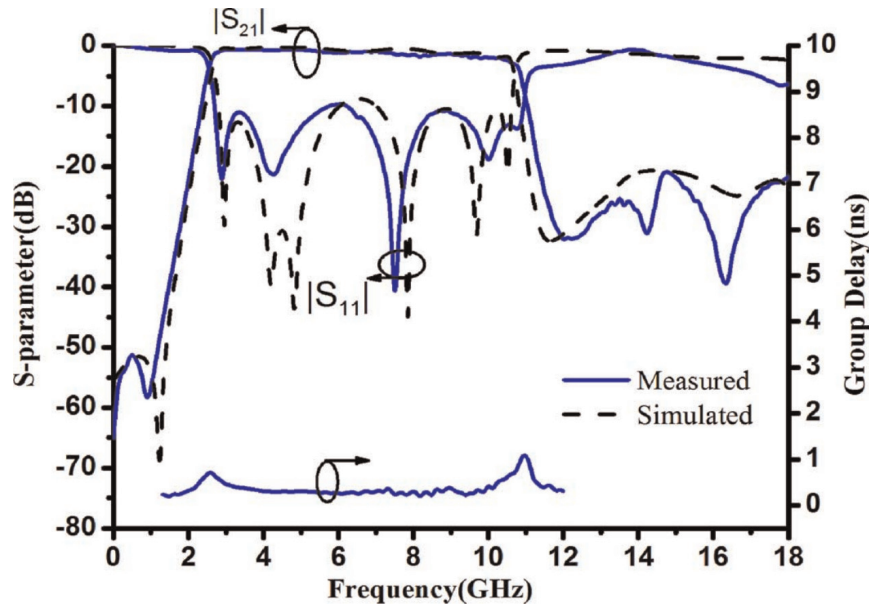

Figure 12. Measured results versus simulated results of fabricated UWB filter.

As depicted in **Figures 14** and **15**, the bandwidth of UWB filter increases as the R_s increases, and the coupling strength and the bandwidth are both decreased as R_L lessens; thus, the bandwidth of UWB filter can be easily tuned by properly adjusting the R_s and R_L , and design parameters are finally chosen as $W_0 = 0.4$, $L_0 = 4$, $W_1 = 0.55$, $L_1 = 4.85$, $W_2 = 0.85$, $L_2 = 5.1$, $W_3 = 1.4$, $L_3 = 4.9$, $W_4 = 2.25$, $L_4 = 4.74$, $W_5 = 3.15$, and $L_5 = 4.1$. For the purpose of validating the design methodology, the dual-layer UWB bandpass filter is fabricated on the substrate of Rogers 6006 with relative permittivity if 6.15 and measured. The measurement results indicate that the proposed UWB filter is of extremely low insertion loss (< 1 dB) and 47 dB stopband suppression up to 17.4 GHz with compact size, which can be observed in **Figure 16**.

4.4 UWB bandpass filters with parallel-coupled lines

The parallel-coupled lines can also employ to design UWB bandpass filter with simple structure. In [47], shorted coupled line structure and $\lambda/4$ shorted stub are introduced to achieve UWB bandpass filter with compact size. The ideal transmission line model of proposed UWB bandpass filter is demonstrated in **Figure 17**.

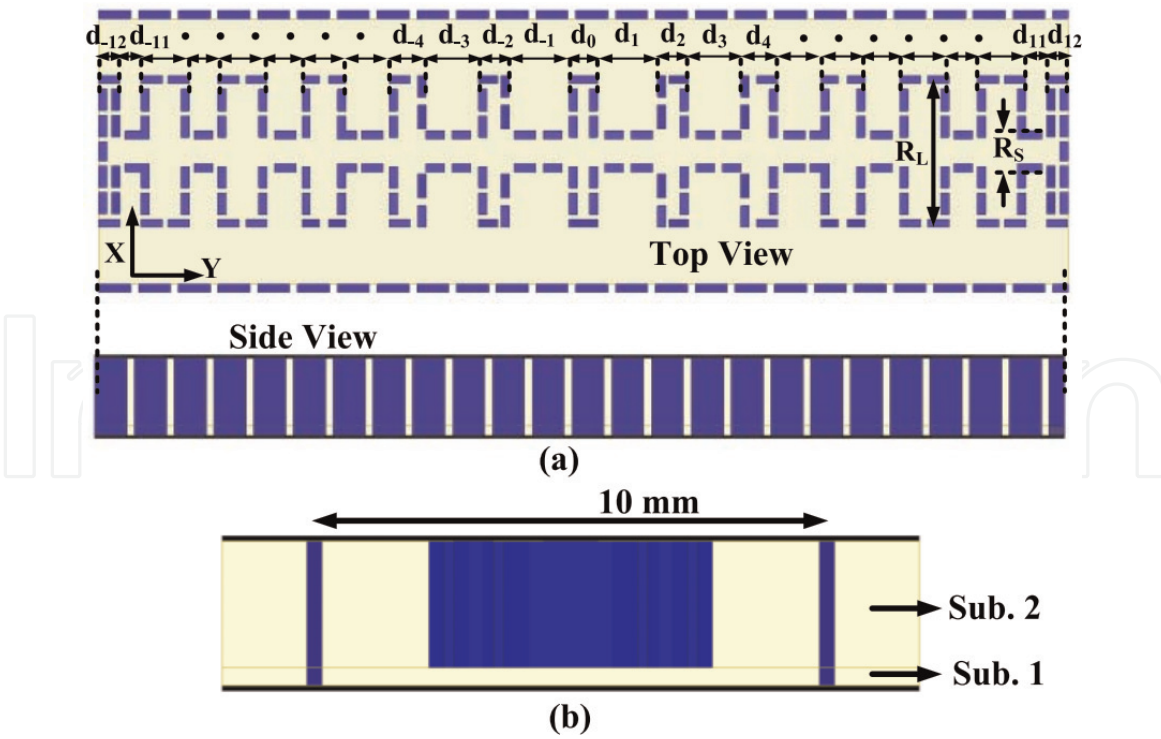

Figure 13. Physical layout of the presented UWB filter. (a) Top band side view. (b) Front view.

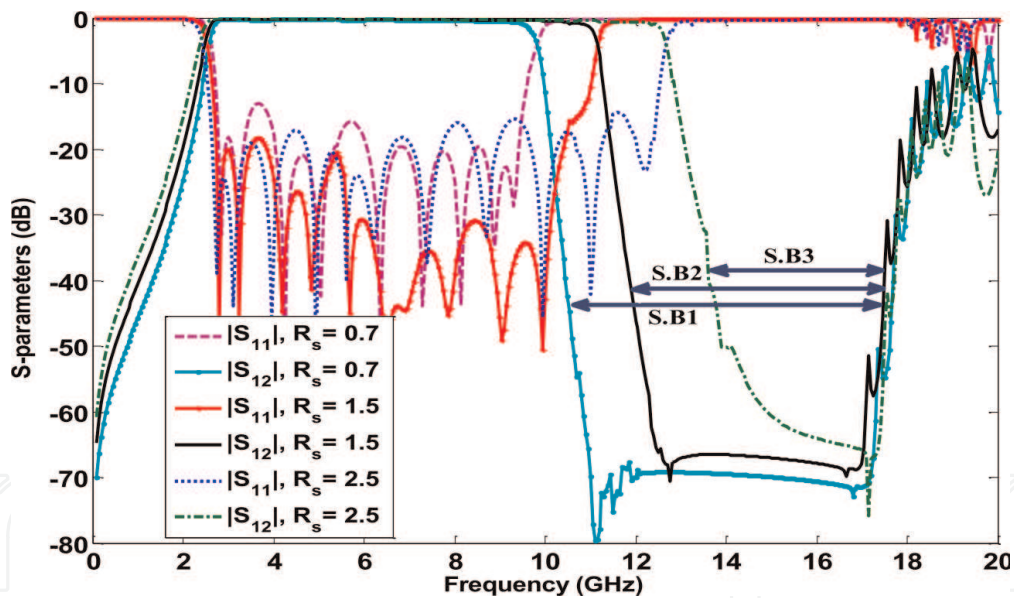

Figure 14. Different transmission characteristics versus varied R_s .

Since the shorted coupled line structure is not a symmetrical structure, the ABCD matrix analysis method is employed to solve the input admittance of the proposed UWB bandpass filter, and the Y-matrix of this filter can be written as

$$Y = Y_{upper} + Y_{lower} \quad (21)$$

where

$$Y_{upper} = \begin{bmatrix} \frac{D}{B} & \frac{BC - AD}{B} \\ -\frac{1}{B} & \frac{A}{B} \end{bmatrix} \quad (22)$$

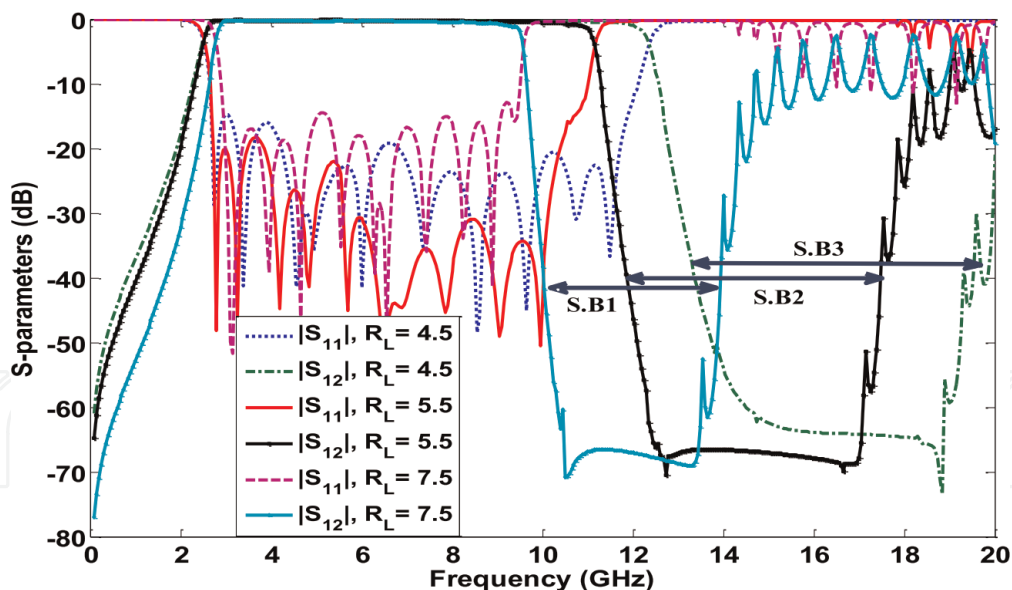

Figure 15.
Variation of frequency responses against varied R_L .

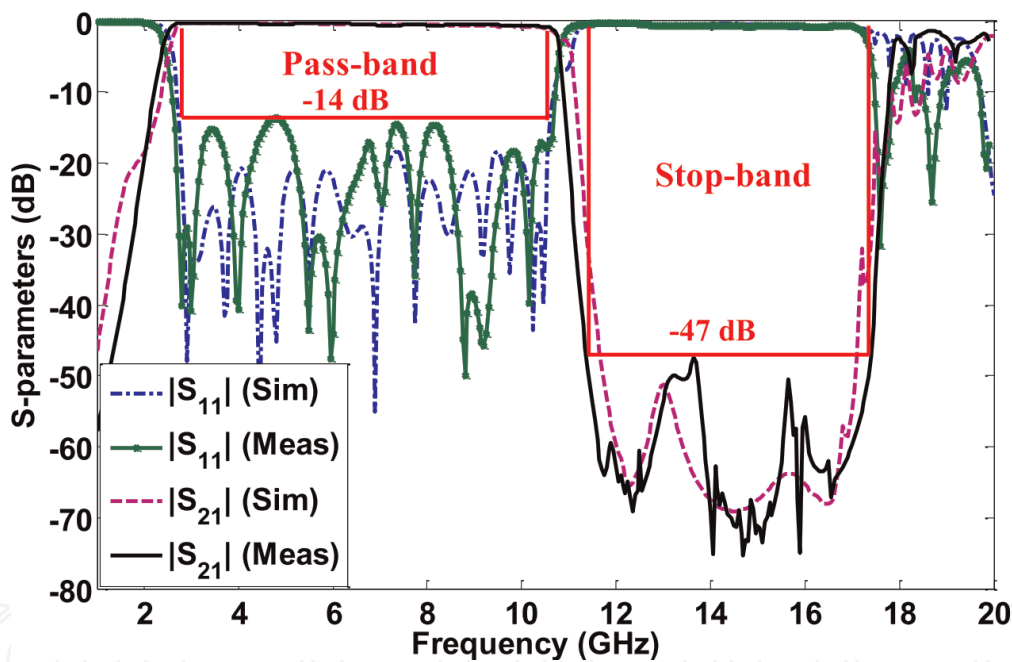

Figure 16.
Measurement results and simulated results of fabricated UWB filter.

where the whole ABCD matrix can be derived by

$$\begin{bmatrix} A & B \\ C & D \end{bmatrix} = M_2 M_3 M_4 M_5 M_6 \quad (23)$$

where

$$M_n = \begin{bmatrix} \cos \theta_n & jZ_n \sin \theta_n \\ j\left(\frac{1}{Z_n}\right) \sin \theta_n & \cos \theta_n \end{bmatrix} \quad (n = 2, 4, 6) \quad (24)$$

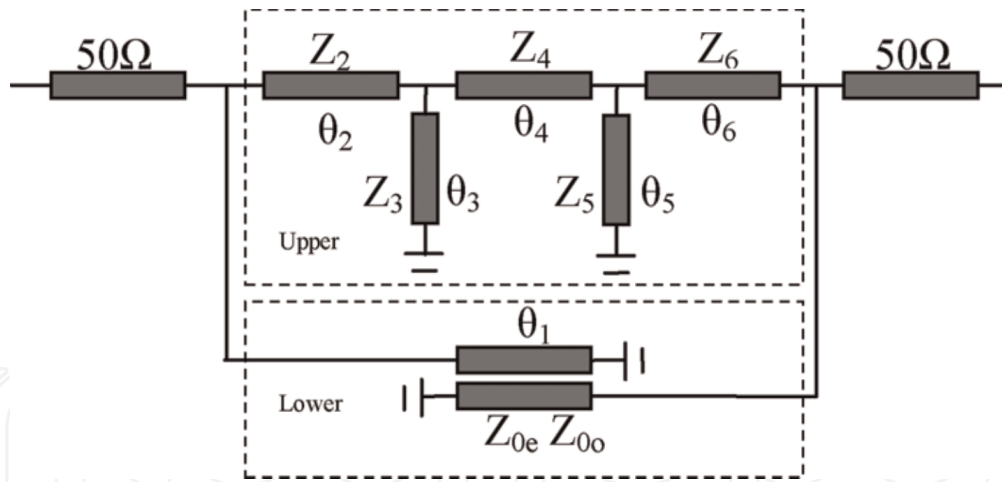

Figure 17.
 Configuration of proposed UWB bandpass filter with shorted coupled lines.

$$M_m = \begin{bmatrix} 1 & 0 \\ \frac{1}{jZ_m \tan \theta_m} & 1 \end{bmatrix} \quad (m = 3, 5) \quad (25)$$

$$Y_{lower} = -j \frac{1}{qZ_0} \begin{bmatrix} \cot \theta_1 & \frac{k}{\sin \theta_1} \\ \frac{k}{\sin \theta_1} & \cot \theta_1 \end{bmatrix} \quad (26)$$

where

$$k = \frac{(Z_{0e} - Z_{0o})}{(Z_{0e} + Z_{0o})} Z_0 = \sqrt{Z_{0o} Z_{0e}} \quad (27)$$

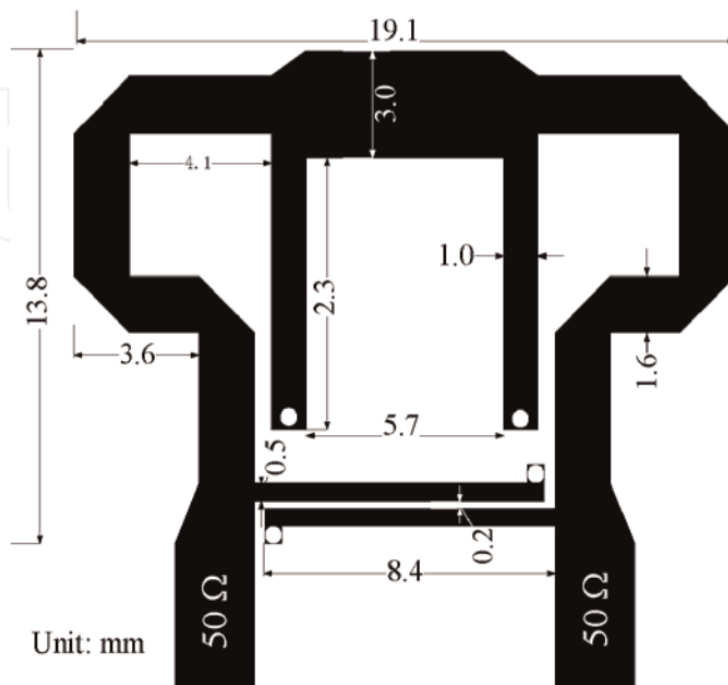

Figure 18.
 Final circuit layout with dimension parameters of presented filter.

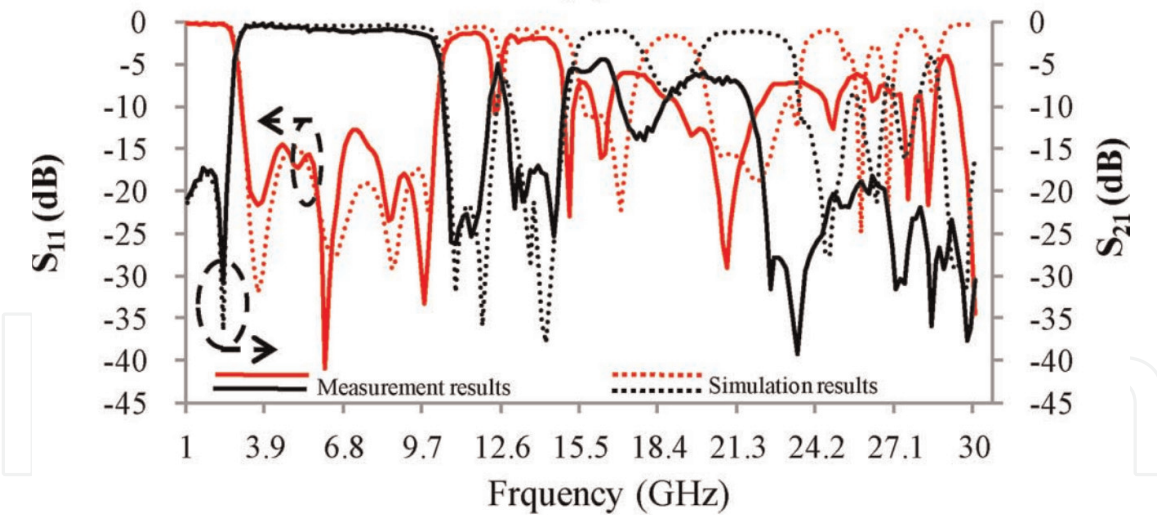

Figure 19.
Simulation and measurement results of presented UWB bandpass filter.

Thus, transmission coefficient can be derived. By properly changing the electrical lengths, UWB bandpass characteristics can be fulfilled, and the dimension parameters can be determined by using full-wave EM simulator, as demonstrated in **Figure 18**. Then simulation results and measurement results of fabricated UWB bandpass filter are shown in **Figure 19**, which shows excellent passband performance and multi-transmission zeros.

5. Microwave UWB bandpass filter with notch band

As illustrated in **Figure 2**, the UWB band has dramatic high FBW and surprisingly 7.5 GHz absolute bandwidth; therefore, the UWB has got great potential in many applications. However, a variety of undesired radio signal interferences and noise exist in the UWB frequency spectrum covering 3.1–10.6 GHz. Such as WiMAX (3.5 GHz), WLAN (5.2 GHz, 5.8 GHz), C-band satellite signals (5.975–6.745 GHz, 6.725–7.025 GHz), and RFID (6.8 GHz). As shown in **Figure 2**, some interference is introduced to the UWB communication system due to these narrowband signals. Thus, several notches are required to filter out the unwanted radio interference signals in UWB communication systems. In general, the methods of introducing a notch band in the UWB bandpass filter is of same essence, which is the electromagnetic energy of a certain frequency absorbed in the UWB band, so that signals with this frequency has been shorted out and averted to transmit from input to the output port. The design of the UWB notch filter has the following two

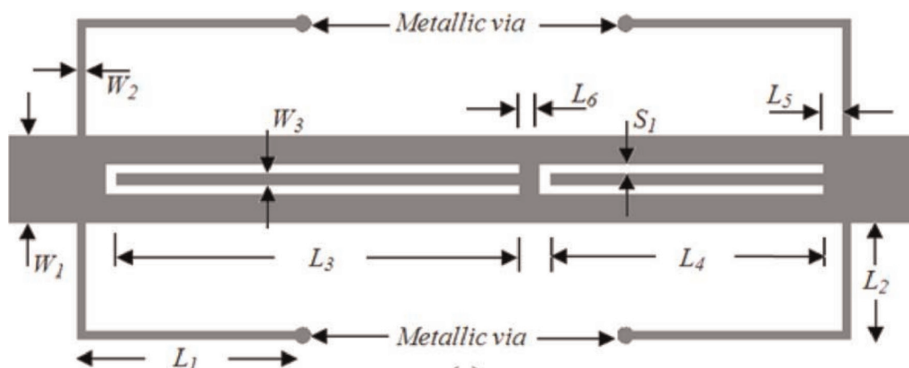

Figure 20.
Top view of the UWB bandpass filter with notch band.

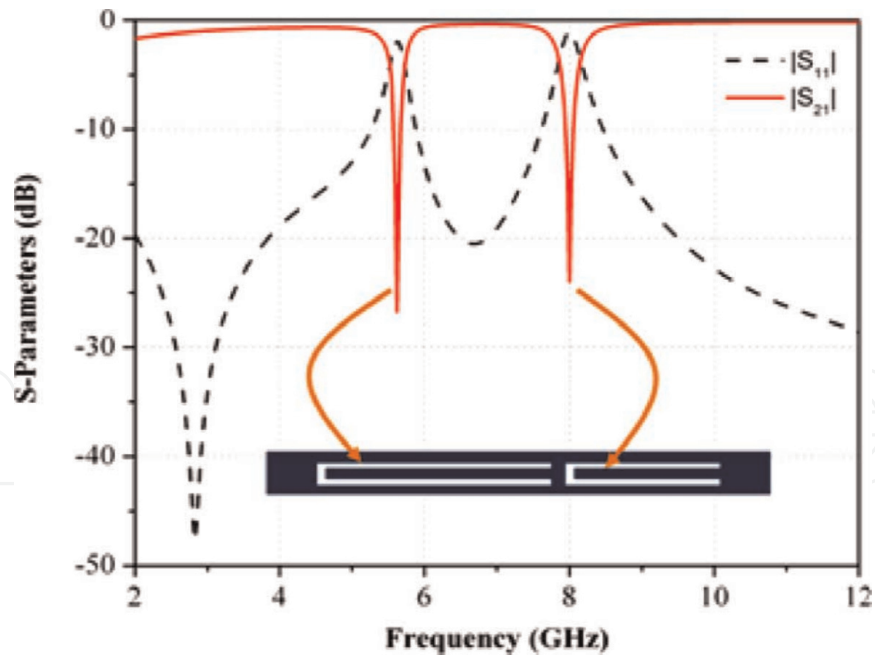

Figure 21.
 The layout diagram of embedded open-circuited stubs and dual-notch band of proposed UWB filter.

methods: first, introducing additional notch unit circuits and, second, introducing lateral signal interference. The notch unit can be realized by various configurations, which includes single-mode/multimode resonator, a defected ground structure resonator, a metamaterial resonator, etc. Ultimately, the purpose of introducing notch unit circuits is to construct an electromagnetic absorption that set a notch in the UWB. Obviously, the notch which is designed based on aforementioned method is independently controllable. Furthermore, the number of notches can be easily extended, such as dual-notch band UWB filter and triple-notch band UWB filter.

To approach UWB bandpass characteristics with notch band, open-ended stubs can be applied to generate electromagnetic absorption [70]. The physical configuration is shown in **Figure 20**. Triple pairs of dumbbell defected ground structure are

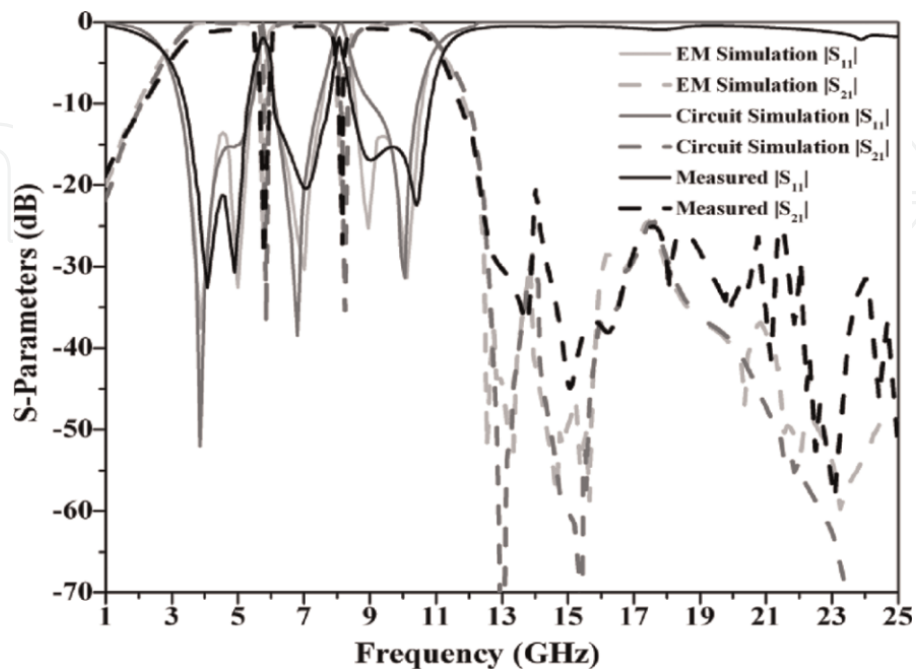

Figure 22.
 EM simulation results versus circuit simulation results versus measurement results of presented UWB notch band bandpass filter.

introduced to realize low-pass transmission characteristics with improved out-of-band performance. Embedded open-circuited stubs are utilized to generate a pair of notch band, which is located at 5.75 and 8.05 GHz, as depicted in **Figure 21**. The developed filter is analyzed by using EM simulator CST microwave and fabricated on TACONIC substrate of dielectric constant 2.2. Excellent agreement can be observed which proves that the proposed UWB bandpass filter is of UWB with dual-notch band characteristics and wide stopband, as illustrated in **Figure 22**.

6. Conclusion

The research significance of the UWB bandpass filters and several conventional methods to achieve UWB bandpass filters with desired transmission performance is reviewed in this chapter. As the key building block of the UWB technology, the UWB bandpass filters can be realized by using several reliable design methodologies with excellent frequency response performance, which is of great value for scientific research and engineering significance.

Author details

Li-Tian Wang¹, Yang Xiong² and Ming He^{1,3*}

1 College of Electronic and Optical Engineering, Nankai University, Tianjin, China

2 Southwest China Institute of Electronic Technology, Chengdu, China

3 China Tianjin Key Laboratory of Optoelectronic Sensor and Sensing Network Technology, Tianjin, China

*Address all correspondence to: heming@nankai.edu.cn

IntechOpen

© 2019 The Author(s). Licensee IntechOpen. This chapter is distributed under the terms of the Creative Commons Attribution License (<http://creativecommons.org/licenses/by/3.0>), which permits unrestricted use, distribution, and reproduction in any medium, provided the original work is properly cited. 

References

- [1] Revision of Part 15 of the Commission's Rules Regarding Ultra-Wideband Transmission System. Washington, DC: FCC; 2002. ET-Docket 98-153
- [2] Shannon CE. A mathematical theory of communication. *Bell Labs Technical Journal*. 1948;**27**(4):379-423. DOI: 10.1002/j.1538-7305.1948.tb00917
- [3] Rappaport TS et al. Millimeter wave mobile communications for 5G cellular: It will work! *IEEE Access*. 2013;**1**: 335-349. DOI: 10.1109/ACCESS.2013.2260813
- [4] Gubbi J et al. Internet of Things (IoT): A vision, architectural elements, and future directions. *Future Generation Computer Systems*. 2013; **29**(7):1645-1660. DOI: 10.1016/j.future.2013.01.010
- [5] Weng MH et al. Design of an ultra-wideband bandpass filter by using coupled three line microstrip structure. *Journal of Electromagnetic Waves and Applications*. 2012;**26**(5-6):716-728. DOI: 10.1080/09205071.2012.710798
- [6] Weng MH et al. A high selectivity and wide stopband UWB bandpass filter using asymmetric SIRs with split-end. *Microwave and Optical Technology Letters*. 2014;**56**(6):1353-1356. DOI: 10.1002/mop.28321
- [7] Wyndrum RW. Microwave filters, impedance-matching networks, and coupling structures. *Proceedings of the IEEE*. 1965;**53**(7):766-766. DOI: 10.1109/PROC.1965.4048
- [8] Pozar DM. *Microwave Engineering*. In: Hoboken J editor. NJ, USA: Wiley; 2006. DOI: 10.1109/45.31588
- [9] Levy R, Cohn SB. A history of microwave filter research, design, and development. *IEEE Transactions on Microwave Theory and Techniques*. 1984;**32**(9):1055-1067. DOI: 10.1109/tmtt.1984.1132817
- [10] Hong J-S, Lancaster MJ. *Microstrip Filters for RF/Microwave Applications*. Hoboken, NJ, USA: John Wiley & Sons, Inc; 2001. DOI: 10.1002/0471221619
- [11] Hsu CL, Hsu FC, Kuo JK. Microstrip bandpass filters for ultra-wideband (UWB) wireless communications. In: *IEEE MTT-S International Microwave Symposium Digest, 2005*. IEEE; 2005. DOI:10.1109/MWSYM.2005.1516698
- [12] Yang GM et al. Design of ultra-wide band (UWB) bandpass filter based on defected ground structure. *Microwave and Optical Technology Letters*. 2010; **49**(6):1374-1377. DOI: 10.1002/mop.22471
- [13] Wu CH et al. A compact LTCC ultra-wideband bandpass filter using semi-lumped parallel-resonance circuits for spurious suppression. In: *Microwave Conference, 2007*. European IEEE; 2007. DOI: 10.1109/EUMC.2007.4405245
- [14] Han L, Wu K, Zhang X. Development of packaged ultra-wideband bandpass filters. *IEEE Transactions on Microwave Theory and Techniques*. 2010;**58**(1):220-228. DOI: 10.1109/tmtt.2009.2036399
- [15] Qing-Xin C, Sai-Wai W. Ultra-wideband bandpass filter technologies. *Journal of Microwaves*. 2013;**29**:172-180
- [16] Ting Z et al. A multi-mode resonator-based UWB bandpass filter with wide stopband. *International Journal of Microwave and Wireless Technologies*. 2016;**8**(7):5. DOI: 10.1017/S1759078715001026
- [17] Ishii H et al. Development of UWB HTS bandpass filters with microstrip

- stubs-loaded three-mode resonator. *IEEE Transactions on Applied Superconductivity*. 2013;**23**(3): 1500204-1500204. DOI: 10.1109/TASC.2012.2232697
- [18] Lim TB, Zhu L. Highly selective differential-mode wideband bandpass filter for UWB application. *IEEE Microwave and Wireless Components Letters*. 2011;**21**(3):133-135. DOI: 10.1109/LMWC.2011.2104357
- [19] Wu XH et al. Quintuple-mode UWB bandpass filter with sharp roll-off and super-wide upper stopband. *IEEE Microwave and Wireless Components Letters*. 2011;**21**(12):661-663. DOI: 10.1109/LMWC.2011.2170672
- [20] Taibi A et al. A novel design method for compact UWB bandpass filters. *IEEE Microwave and Wireless Components Letters*. 2015;**25**(1):4-6. DOI: 10.1109/LMWC.2014.2363016
- [21] Lan SW et al. Design of a compact ultra-wideband bandpass filter with an extremely broad stopband region. *IEEE Microwave and Wireless Components Letters*. 2016;**26**(6):1-3. DOI: 10.1109/LMWC.2016.2558039
- [22] Gao X, Feng W, Che W. Compact ultra-wideband bandpass filter with improved upper stopband using open/shorted stubs. *IEEE Microwave and Wireless Components Letters*. 2017;**27**(2):123-125. DOI: 10.1109/LMWC.2016.2647385
- [23] Tianliang Z et al. High-temperature superconducting multimode ring resonator ultrawideband bandpass filter. *IEEE Microwave and Wireless Components Letters*. 2018:1-3. DOI: 10.1109/LMWC.2018.2845116
- [24] Yao B et al. Compact UWB bandpass filter with improved upper-stopband performance using multiple-mode resonator. *IEEE Microwave and Wireless Components Letters*. 2009;**19**(1):27-29. DOI: 10.1109/LMWC.2008.2008558
- [25] Zhang Z, Xiao F. An UWB bandpass filter based on a novel type of multi-mode resonator. *IEEE Microwave and Wireless Components Letters*. 2012;**22**: 506-508. DOI: 10.1109/LMWC.2012.2218229
- [26] Hong J-S, Shaman H. An optimum ultra-wideband microstrip filter. *Microwave and Optical Technology Letters*. 2010;**47**(3):230-233. DOI: 10.1002/mop.21133
- [27] Wong WT et al. Highly selective microstrip bandpass filters for ultra-wideband (UWB) applications. In: *Asia-Pacific Microwave Conference Proceedings, 2005 (APMC 2005)*. IEEE; 2006
- [28] Shaman H, Hong JS. A novel ultra-wideband (UWB) bandpass filter (BPF) with pairs of transmission zeroes. *IEEE Microwave and Wireless Components Letters*. 2007;**17**(2):121-123. DOI: 10.1109/LMWC.2006.890335
- [29] Shaman H, Hong JS. An optimum ultra-wideband (UWB) bandpass filter with spurious response suppression. In: *IEEE Wireless & Microwave Technology Conference; 2007*. DOI: 10.1109/WAMICON.2006.351902
- [30] Deng HW et al. Compact quintuple-mode stub-loaded resonator and UWB filter. *IEEE Microwave and Wireless Components Letters*. 2010;**20**(8): 438-440. DOI: 10.1109/LMWC.2010.2049481
- [31] Zhu H, Chu QX. Compact ultra-wideband (UWB) bandpass filter using dual-stub-loaded resonator (DSLRL). *IEEE Microwave and Wireless Components Letters*. 2013;**23**(10): 527-529. DOI: 10.1109/LMWC.2013.2278278
- [32] Chu QX, Wu XH, Tian XK. Novel UWB bandpass filter using stub-loaded

- multiple-mode resonator. *IEEE Microwave and Wireless Components Letters*. 2011;**21**(8):403-405. DOI: 10.1109/lmwc.2011.2160526
- [33] Zhu L, Sun S, Menzel W. Ultra-wideband (UWB) bandpass filters using multiple-mode resonator. *IEEE Microwave and Wireless Components Letters*. 2005;**15**(11):796-798. DOI: 10.1109/lmwc.2005.859011
- [34] Wong SW, Zhu L. Quadruple-mode UWB bandpass filter with improved out-of-band rejection. *IEEE Microwave and Wireless Components Letters*. 2009;**19**(3):152-154. DOI: 10.1109/LMWC.2009.2013735
- [35] Chu QX, Tian XK. Design of UWB bandpass filter using stepped-impedance stub-loaded resonator. *IEEE Microwave and Wireless Components Letters*. 2010;**20**(9):501-503. DOI: 10.1109/LMWC.2010.2053024
- [36] Lu X et al. Superconducting ultra-wideband (UWB) bandpass filter design based on quintuple/quadruple/triple-mode resonator. *IEEE Transactions on Microwave Theory and Techniques*. 2015;**63**(4):1281-1293. DOI: 10.1109/tmtt.2015.2402152
- [37] Shang Z et al. Design of a superconducting ultra-wideband (UWB) bandpass filter with sharp rejection skirts and miniaturized size. *IEEE Microwave and Wireless Components Letters*. 2013;**23**(2):72-74. DOI: 10.1109/LMWC.2013.2239633
- [38] Ishida H, Araki K. Design and analysis of UWB band pass filter with ring filter. In: 2004 IEEE MTT-S International IEEE Microwave Symposium Digest; 2004. DOI: 10.1109/MWSYM.2004.1338806
- [39] Sun S, Zhu L. Wideband microstrip ring resonator bandpass filters under multiple resonances. *IEEE Transactions on Microwave Theory and Techniques*. 2007;**55**(10):2176-2182. DOI: 10.1109/tmtt.2007.906510
- [40] Lok U, Chiou YC, Kuo JT. Quadruple-mode coupled-ring resonator bandpass filter with quasi-elliptic function passband. *IEEE Microwave and Wireless Components Letters*. 2008;**18**(3):179-181. DOI: 10.1109/LMWC.2008.916782
- [41] Wong SW, Zhu L, Quek LC, Chen ZN. A stopband-enhanced UWB bandpass filter using short-/open-stubs embedded ring resonator. In: *IEEE Microwave Conference; 2009*. DOI: 10.1109/APMC.2009.5384314
- [42] Kim CH, Chang K. Ring resonator bandpass filter with switchable bandwidth using stepped-impedance stubs. *IEEE Transactions on Microwave Theory and Techniques*. 2010;**58**(12):5609230. DOI: 10.1109/tmtt.2010.2084584
- [43] Fan J et al. Wideband microstrip bandpass filter based on quadruple mode ring resonator. *IEEE Microwave and Wireless Components Letters*. 2012;**22**(7):348-350. DOI: 10.1109/LMWC.2012.2199977
- [44] Kim CH, Chang K. Ultra-wideband (UWB) ring resonator bandpass filter with a notched band. *IEEE Microwave and Wireless Components Letters*. 2011;**21**(4):206-208. DOI: 10.1109/LMWC.2011.2109942
- [45] Xu KD et al. Compact ultra-wideband bandpass filter using quad-T-stub-loaded ring structure. *Microwave and Optical Technology Letters*. 2014;**56**(9):1988-1991. DOI: 10.1002/mop.28508
- [46] Oh S, Song J, Lee J. UWB bandpass filter based on ring resonator. *Microwave and Optical Technology Letters*. 2013;**55**(9):2047-2051. DOI: 10.1002/mop.27780

- [47] Li X, Ji X. Novel compact UWB bandpass filters design with cross-coupling between $\Lambda/4$ short-circuited stubs. *IEEE Microwave and Wireless Components Letters*. 2014; **24**(1):23-25. DOI: 10.1109/LMWC.2013.2287231
- [48] Abbosh AM. Design method for ultra-wideband bandpass filter with wide stopband using parallel-coupled microstrip lines. *IEEE Transactions on Microwave Theory and Techniques*. 2012; **60**(1):31-38. DOI: 10.1109/tmtt.2011.2175241
- [49] Luo X et al. Compact ultra-wideband (UWB) bandpass filter with ultra-narrow dual- and quad-notched bands. *IEEE Transactions on Microwave Theory and Techniques*. 2011; **59**(6): 1509-1519. DOI: 10.1109/tmtt.2011.2116800
- [50] Nedil M et al. Ultra-wideband bandpass filters using multilayer slot coupled transitions. *Journal of Electromagnetic Waves and Applications*. 2008; **22**(4):501-516. DOI: 10.1163/156939308784150353
- [51] Hao ZC, Hong JS. Ultra wideband bandpass filter using embedded stepped impedance resonators on multilayer liquid crystal polymer substrate. *IEEE Microwave and Wireless Components Letters*. 2008; **18**(9):581-583. DOI: 10.1109/LMWC.2008.2002448
- [52] Hao ZC, Hong JS. Compact ultra-wideband bandpass filter using broadside coupled hairpin structures on multilayer liquid crystal polymer substrate. *Electronics Letters*. 2008; **44**(20):1197-1198. DOI: 10.1049/el:20089877
- [53] Hao ZC, Hong JS. Quasi-elliptic UWB bandpass filter using multilayer liquid crystal polymer technology. *IEEE Microwave and Wireless Components Letters*. 2010; **20**(4):202-204. DOI: 10.1109/LMWC.2010.2042551
- [54] Hao ZC, Hong JS. UWB bandpass filter using cascaded miniature high-pass and low-pass filters with multilayer liquid crystal polymer technology. *IEEE Transactions on Microwave Theory and Techniques*. 2010; **58**(4):941-948. DOI: 10.1109/tmtt.2010.2042632
- [55] Li Y et al. Novel multilayered ultra-broadband bandpass filters on high-impedance slotline resonators. *IEEE Transactions on Microwave Theory and Techniques*. 2019; **67**(1):129-139. DOI: 10.1109/TMTT.2018.2873330
- [56] Honari MM et al. Two-layered substrate integrated waveguide filter for UWB applications. *IEEE Microwave and Wireless Components Letters*. 2017; **27**(7):1-3. DOI: 10.1109/lmwc.2017.2711510
- [57] Hao ZC, Hong JS. Ultra-wideband bandpass filter using multilayer liquid-crystal-polymer technology. *IEEE Transactions on Microwave Theory and Techniques*. 2008; **56**(9):2095-2100. DOI: 10.1109/tmtt.2008.2002228
- [58] Xu J et al. Compact UWB bandpass filter with a notched band using radial stub loaded resonator. *IEEE Microwave and Wireless Components Letters*. 2012; **22**(7):351-353. DOI: 10.1109/LMWC.2012.2201930
- [59] Gomez-Garcia R et al. High-order planar bandpass filters with electronically-reconfigurable passband width and flatness based on adaptive multi-resonator cascades. *IEEE Access*. 2019; **99**:1-1. DOI: 10.1109/ACCESS.2019.2891889
- [60] Ghatak R et al. A compact UWB bandpass filter with embedded sir as band notch structure. *IEEE Microwave and Wireless Components Letters*. 2011; **21**(5):261-263. DOI: 10.1109/LMWC.2011.2128302
- [61] Xu HX, Wang GM, Zhang CX. Fractal-shaped UWB bandpass filter based on composite right/left handed

transmission line. *Electronics Letters*. 2010;**46**(4):285-287. DOI: 10.1049/el.2010.3139

[62] Wei F et al. Compact UWB bandpass filter with dual notched bands based on SCRLH resonator. *IEEE Microwave and Wireless Components Letters*. 2011;**21**(1):28-30. DOI: 10.1109/LMWC.2010.2088113

[63] Shaman H. Ultra-wideband (UWB) bandpass filter with embedded band notch structures. *IEEE Microwave and Wireless Components Letters*. 2007;**17**:193-195. DOI: 10.1109/LMWC.2006.890467

[64] Yang GM et al. Small ultra-wideband (UWB) bandpass filter with notched band. *IEEE Microwave and Wireless Components Letters*. 2008;**18**(3):176-178. DOI: 10.1109/LMWC.2008.916781

[65] Wang H et al. Cross-shaped UWB bandpass filter with sharp skirt and notched band. *Electronics Letters*. 2012;**48**(2):96-97. DOI: 10.1049/el.2011.3694

[66] Hao Z-C et al. Ultra-wideband bandpass filter with multiple notch-bands on multilayer liquid crystal polymer substrate. *IET Microwaves, Antennas and Propagation*. 2009;**3**(5):749-756. DOI: 10.1049/iet-map.2008.0232

[67] Luo X et al. Compact UWB bandpass filter with ultra narrow notched band. *IEEE Microwave and Wireless Components Letters*. 2010;**20**(3):145-147. DOI: 10.1109/LMWC.2010.2040212; 10.1109/tmmt.2011.2116800

[68] Gupta SC, Kumar M, Meena RS. Design & analysis of a microstrip line multi band UWB filter. *AEU - International Journal of Electronics and Communications*. 2016;**70**:1556-1564. DOI: 10.1016/j.aeue.2016.09.014

[69] Yan T et al. High-selectivity UWB bandpass filter with a notched band

using stub-loaded multi-mode resonator. *AEU - International Journal of Electronics and Communications*. 2016;**70**(12):1617-1621. DOI: 10.1016/j.aeue.2016.09.016

[70] Sarkar P et al. Compact UWB bandpass filter with dual notch bands using open circuited stubs. *IEEE Microwave and Wireless Components Letters*. 2012;**22**(9):453-455. DOI: 10.1109/LMWC.2012.2210395

[71] Pirani S, Nourinia J, Ghobadi C. Band-notched UWB BPF design using parasitic coupled line. *IEEE Microwave and Wireless Components Letters*. 2010;**20**(8):444-446. DOI: 10.1109/LMWC.2010.2049830

[72] Zhang XY, Zhang YW, Xue Q. Compact band-notched UWB filter using parallel resonators with a dielectric overlay. *IEEE Microwave and Wireless Components Letters*. 2013;**23**(5):252-254. DOI: 10.1109/LMWC.2013.2255121

[73] Song K et al. Compact ultra-wideband (UWB) bandpass filters with multiple notched bands. *IEEE Microwave and Wireless Components Letters*. 2010;**20**(8):447-449. DOI: 10.1109/LMWC.2010.2050303

[74] Wei F et al. Compact UWB bandpass filter with triple-notched bands using triple-mode stepped impedance resonator. *IEEE Microwave and Wireless Components Letters*. 2012;**22**(10):512-514. DOI: 10.1109/LMWC.2012.2215845

[75] Zhao J et al. Compact microstrip UWB bandpass filter with dual notched bands using e-shaped resonator. *IEEE Microwave and Wireless Components Letters*. 2013;**23**(12):638-640. DOI: 10.1109/LMWC.2013.2283873

[76] Sekar V, Entesari K. Miniaturized UWB bandpass filters with notch using slow-wave CPW multiple-mode

resonators. *IEEE Microwave and Wireless Components Letters*. 2011; **21**(2):80-82. DOI: 10.1109/LMWC.2010.2096803

[77] Song Y, Yang GM, Geyi W. Compact UWB bandpass filter with dual notched bands using defected ground structures. *IEEE Microwave and Wireless Components Letters*. 2014; **24**(4):230-232. DOI: 10.1109/LMWC.2013.2296291

IntechOpen