

MECHANICS OF NON-UNIFORM WEBS

by

R. P. Swanson
3M Company
USA

ABSTRACT

This paper lays the groundwork in an effort to determine appropriate boundary conditions and basic principles that can be used to extend current web mechanics models to include webs that are not "initially straight and uniform". A method to design, manufacture, measure and test non-uniform web is presented. Deflection, shear and moment equations are extended to include the effects of cambered web and non-zero curvature at the downstream end of a span. It is shown that the curvature at the downstream roller is not zero, as is the case with uniform web. The prediction of actual curvature, and consequently deflection, shear and moment, has been bracketed, but not quantified.

NOMENCLATURE

C	Numerical constant
D	Distance used in camber measurement
E	Young's modulus of the web
e	Web eccentricity
I	Moment of inertia
K	Shelton's constant
L	Span length
M	Moment at the downstream end of the span
N	Shear force
T	Tension
t	Web thickness
W	Web width
y	Lateral deflection

θ	Angle
ϕ	Roller taper angle
ρ	Radius of curvature
Subscripts:	
0	X=0, upstream end of the beam
L	X=L, Downstream end of the beam
cr	critical
M	Referring to moment M
N	Referring to shear force N
web	Referring to non-tensioned web

INTRODUCTION

All webs have some degree of crossweb non-uniformity in machine direction length. Non-uniform or "baggy" web can be in the form of camber, baggy lanes or slack edges. Baggy web causes, or compounds, problems such as lateral motion and wrinkling, especially at processes that require nips, such as laminating and some coating methods.

Background

The mechanics of uniform web has been extensively studied and models have been developed to predict web stress, lateral behavior and wrinkling. These models use appropriate boundary conditions and basic principles such as normal entry, moment transfer and beam theory. A common assumption in most of these models is that the web is "initially straight and uniform". Three papers have previously been published that deal with the mechanics of uniform and non-uniform webs.

Shelton [1] and [2]

"Lateral Dynamics of a Moving Web" [1] was the original effort in web mechanics. The web statics section established four boundary conditions, the first of which was the establishment of the coordinate system. The second and third were normal entry and exit of a moving web, as a consequence of steady state conditions. The fourth boundary condition, zero moment (curvature) at the downstream roller, was determined when experimental evidence left no other option. These boundary conditions were used to solve a fourth order differential equation, resulting in equations that model static deflection, moment and shear. Shear and deflection measurements were used to verify the model.

"Effects of Cambered Web on Handling" [2] discussed web camber and the problems associated with the handling of cambered webs, and several useful equations were presented. The length (L) of the sample and distance (D), between a straight line (chord) and the edge of the web, were used in equation (1) to calculate the radius of curvature of the web swept out flat on the floor. Equations (2) and (3) describe the relationships for critical tension, the minimum tension required to eliminate slackness in all parts of the web.

A mechanism, called induced taper, was introduced to explain why webs have been observed to deflect to the baggy side. The low-tension side of the web would ride higher on the roller and therefore behave as a tapered roller. This paper will suggest that the magnitude of induced taper and its relationship with span length are inconsistent with experimental results.

$$\rho_{web} = \frac{L^2}{8D} \quad (1)$$

$$M_{web} = \frac{T_{cr}W}{6} \quad (2)$$

$$T_{cr} = \frac{EtW^2}{3\rho_{web}} \quad (3)$$

Swanson [3]

"Air Support Conveyance of Uniform and Non-Uniform Webs" described the mechanics of cambered webs. Three solutions were presented including a numerical model, a finite element model and a closed form (6) equation. The Shelton's [1] first three boundary conditions were used: $y(x=0)=0$, $y'(x=0)=0$ and $y'(x=L)=\theta_L$. The fourth boundary condition equation (4) was used for short spans and equation (5) was used for long spans or poor traction. One consequence of the short span boundary condition was that the web would not deflect or have induced shear. This paper will show that this conclusion is not correct and that very small deflections and shears do exist. The actual fourth boundary condition ranges between the extremes, of equations (4) and (5).

Short Span boundary condition:

$$y''_{x=L} = 0 \quad (4)$$

Long Span or partial traction boundary condition:

$$y''_{x=L} = \frac{M_{web}}{EI} \quad (5)$$

$$y(x) = -e \left(1 - \cosh(Kx) + \frac{\sinh(KL)}{1 - \cosh(KL)} (Kx - \sinh(Kx)) \right) \quad (6)$$

$$e = \frac{M_{web}}{T} \quad (7)$$

Dobbs and Kedl [4]

"Wrinkle Dependency on Web Roller Slip" described how moment could transfer across a roller. When bending moment was applied to a web span, the tension increased on one edge of the web and decreased on the other. When sufficient moment was applied, the roller was no longer able to support the tension differential across the roller, at its edges. High tension transferred across on one edge and low tension transferred on the other edge, creating a moment in the adjacent span, as shown in Figure (1a). The roller never slipped in the middle of the width because the tension was the same on both side of the roller. Therefore, the roller had normal entry ($y'=0$), but the moment or curvature (y'') was not zero. Cambered web, would have non-uniform crossweb tension, appearing symmetrically on both sides of the roller, as shown in Figure (1b) and therefore little chance of moment transfer.

MECHANICS OF CAMBERED WEBS

"Lateral Dynamics of a Moving Web" [1] assumed an initially straight and uniform web. Verification experiments were careful to use non-cambered web because an offset noted in the shear data with cambered web. Shelton's fourth boundary condition $y''_L=0$, which was extended to non-uniform web with short spans, by Swanson in "Air Support Conveyance of Uniform and Non-Uniform Webs" [3] does not account for this offset.

Shelton also solved the equation using $y''_L=CM_0/EI$ and plotted results for C as low as 0.05 against the experimentally measured shear. This was used to prove that the moment had truly gone to zero at the downstream roll, and was not just a small fraction of the upstream moment. This solution can not be used for the case of a cambered web moving over trammed rollers because M_0 would be equal to zero and the equation would revert to the original solution for a straight and uniform web.

Equations (8)-(24) solve the differential equation for the more generic case of a constant moment (curvature) at the downstream roller. Figure (2) illustrates the coordinate system and sign convention.

$$\text{Beam Equation:} \quad M = -EIy'' \quad (8)$$

$$\text{Differential Equation:} \quad y'''' - K^2 y'' = 0 \quad (9)$$

$$K^2 = \frac{T}{EI} \quad (10)$$

General Solution:

$$y = C_1 \sinh(Kx) + C_2 \cosh(Kx) + C_3 x + C_4 \quad (11)$$

$$y' = C_1 K \cosh(Kx) + C_2 K \sinh(Kx) + C_3 \quad (12)$$

$$y'' = C_1 K^2 \sinh(Kx) + C_2 K^2 \cosh(Kx) \quad (13)$$

$$y''' = C_1 K^3 \cosh(Kx) + C_2 K^3 \sinh(Kx) \quad (14)$$

$$y'''' = C_1 K^4 \sinh(Kx) + C_2 K^4 \cosh(Kx) \quad (15)$$

Boundary Condition #1: (coordinate axis)

$$y_0 = 0 \quad (16)$$

Boundary Condition #2: (normal entry from the previous span)

$$y'_0 = 0 \quad (17)$$

Boundary Condition #3: (normal entry)

$$y'_L = \theta \quad (18)$$

Boundary Condition #4: Downstream Moment:

$$M_L = \text{Constant} \therefore y''_L = -\frac{C}{EI} = -\frac{1}{\rho_L} \quad (19)$$

Equations (12)-(19) were used to determine the following constants for the general solution (11).

$$C_1 = \left[-\frac{\theta_L}{K} + \frac{1}{K^2 \rho_L} \frac{\sinh(KL)}{\cosh(KL)} \right] \left[\frac{\cosh(KL)}{\cosh(KL) - 1} \right] \quad (20)$$

$$C_2 = \left[\frac{\theta_L}{K} - \frac{1}{K^2 \rho_L} \frac{\cosh(KL) - 1}{\sinh(KL)} \right] \left[\frac{\sinh(KL)}{\cosh(KL) - 1} \right] \quad (21)$$

$$C_3 = \left[-\theta_L + \frac{1}{K \rho_L} \frac{\sinh(KL)}{\cosh(KL)} \right] \left[\frac{\cosh(KL)}{\cosh(KL) - 1} \right] \quad (22)$$

$$C_4 = \left[-\frac{\theta_L}{K} + \frac{1}{K^2 \rho_L} \frac{\cosh(KL) - 1}{\sinh(KL)} \right] \left[\frac{\sinh(KL)}{\cosh(KL) - 1} \right] \quad (23)$$

$$\begin{aligned} \frac{y}{L} = & \theta_L \left[\frac{\cosh(KL)}{\cosh(KL) - 1} \left(\frac{x}{L} - \frac{\sinh(KL)}{KL} \right) + \frac{1}{KL} \frac{\sinh(KL)}{\cosh(KL) - 1} (\cosh(Kx) - 1) \right] \\ & + \frac{1}{K \rho_L} \left[-\frac{\sinh(KL)}{\cosh(KL) - 1} \left(\frac{x}{L} - \frac{\sinh(KL)}{KL} \right) - \frac{1}{KL} (\cosh(Kx) - 1) \right] \end{aligned} \quad (24)$$

Equation (24) is the superposition of two terms one linear with θ_L and the other linear with $1/\rho_L$. The θ_L term is Shelton's equation for static deflection. The $1/\rho_L$ term is the deflection due to a curvature, or non-zero moment, at the downstream roller.

If $\theta_L=0$, then deflection at the end of the trammed span is given by equation (25).

$$\frac{y_L}{L} = \frac{1}{K \rho_L} \left[-\frac{\sinh(KL)}{\cosh(KL) - 1} \left(1 - \frac{\sinh(KL)}{KL} \right) - \frac{1}{KL} (\cosh(KL) - 1) \right] \quad (25)$$

The moment and shear can also be calculated (26) as superpositions of two equations, one linear with θ_L and the other linear with $1/\rho_L$. The θ_L term is Shelton's moment or shear equation. The $1/\rho_L$ term is the moment or shear due to a curvature, or non-zero moment, at the downstream roller.

$$M = -\frac{TL}{KL} \left[\theta_L \left[\frac{\sinh(KL)}{\cosh(KL) - 1} \cosh(Kx) - \frac{\cosh(KL)}{\cosh(KL) - 1} \sinh(Kx) \right] + \frac{1}{K \rho_L} \left[\frac{\sinh(KL)}{\cosh(KL) - 1} \sinh(Kx) - \cosh(Kx) \right] \right] \quad (26)$$

$$N = T \left[\begin{array}{l} \theta_L \left[\frac{\cosh(KL)}{\cosh(KL) - 1} \cosh(Kx) - \frac{\sinh(KL)}{\cosh(KL) - 1} \sinh(Kx) \right] \\ + \frac{1}{K\rho_L} \left[\sinh(Kx) - \frac{\sinh(KL)}{\cosh(KL) - 1} \cosh(Kx) \right] \end{array} \right] \quad (27)$$

Equation (27) can be used to explain why Shelton noted an offset in his right vs. left shear force readings with cambered web. If $\theta_L=0$ then the shear becomes:

$$N_0 = N_L = -\frac{T}{K\rho_L} \left[\frac{\sinh(KL)}{\cosh(KL) - 1} \right] \quad (28)$$

Cantilever Beam Equations

Most web handling situations have KL values ranging from 0.5 to 10. This means that beam effects dominate the tension effect and the situation can be accurately modeled with simple beam theory. It is also interesting to note that equations (24) (26) and (27) reduce to (37) (35) and (36) when $\theta_L=0$ and taken in the limit as KL goes to zero. The former equations are more general, but simple beam equations may offer more insight into the mechanics of the situation.

Deflection and rotation due to a shear at the end of the beam:

$$Y_L = \frac{NL^3}{3EI} \quad (29)$$

$$\theta_L = \frac{NL^2}{2EI} \quad (30)$$

Deflection and rotation due to a moment at the end of the beam:

$$Y_L = -\frac{M_L L^2}{2EI} \quad (31)$$

$$\theta_L = -\frac{M_L L}{EI} \quad (32)$$

Normal entry boundary condition for tram rollers:

$$\theta_L(M_L) + \theta_L(N) = 0 \quad (33)$$

Superposition of linear solutions:

$$Y_L = Y_L(M_L) + Y_L(N) \quad (34)$$

Equations (24)-(34) can be combined to obtain:

$$M_L = \frac{NL}{2} \quad (35)$$

$$N = \frac{2M_L}{L} \quad (36)$$

$$Y_L = \frac{1}{6} \frac{M_L L^2}{EI} \quad (37)$$

$$Y_L = \frac{1}{12} \frac{NL^3}{EI} \quad (38)$$

$$\frac{Y_L}{N} = \frac{1}{12} \frac{L^3}{EI} \quad (39)$$

EXPERIMENTAL METHODS

A process to engineer and manufacture non-uniform web, for experimental purposes, is presented. This method was used to produce web with varying degrees of non-uniformity. Two measurement techniques of quantifying “baggy” web are compared to each other.

A special apparatus was set up to measure the shear force and lateral displacement of non-uniform web in a trammed test span. Independent variables of span length, camber, tension and roller type (traction) were changed to determine the response of dependent variables, shear force and lateral displacement. The results of these experiments are compared to model predictions.

Manufacture and Measurement of Cambered Web

Uniformly cambered bi-axially oriented polyester (PET) was produced by inserting triangular shims of PET near the core of a roll were wound with high tension and pack force. The triangular shims produced a tapered surface to the roll, resulting in a tapered stress distribution in the rolls. The rolls were baked overnight at 70 C (160 F), causing the web to visco-elastically deform. When unwound, the web had a crossweb tension profile slightly less than the original induced stress.

The web camber could now be measured using Shelton's[2] technique of sweeping the web on the floor, measuring the chord height, and using equations (1) - (3) to determine ρ_{web} , M_{web} , and T_{cr} . A device was also used to measure the crossweb tension midspan between two idler rollers. Analysis of the crossweb profile was used to determine T_{cr} . Figure (3) illustrates a typical cross-web tension plot of a web held at critical tension. Figure (4) show reasonably good correlation between the chord height and cross-web tension measurement techniques.

Measurement of Shear Force and Deflection

Unlike shear force due to tram error, the effects of cambered web can not be isolated in a single span. An intermediate roller would have a shear in one direction from the entry span and the opposite direction from the exit span. The only resultant measurable shear would be differences due to the effect of span lengths.

It has been shown by Dobbs and Kedl [6] that moment can be directly measured, but the technique is a very difficult. Because of the difficulty in measuring moment, these experiments used shear force measurements. A unwind stand was built that was mounted on a near frictionless four bar linkage, as shown in Figure(5). The shear force was measured with a sensitive loadcell and data acquisition system with a resolution of about 0.04 N (0.001 lbs). The measurement resolution was much better than the noise in the system, and repeatable measurements were obtained by averaging over several revolutions of the unwinding roll.

Deflection was measured by using special edge sensors with a resolution of about 0.025 mm (0.001 in.). Four sensors were used, one on each side of the web as close as possible the beginning and end of the span. The deflection measurements were corrected for position along each edge. Zero was established by averaging the left and right side readings of several different uniform webs. Deflections were obtained by averaging of the left and right side readings and subtracting out the zero readings. Discrepancy between the left and right readings usually indicated a wrinkle or trough condition. Wrinkles would commonly occur in the transition area between tensioned and untensioned web, if the overall tension was below the critical tension.

Shear Force and Deflection Experiment

A 2^{4-1} designed experiment was done that looked at the variables of tension, camber, right vs. left and roller coefficient of friction. The results of this experiment showed that webs, even in short spans deflect toward the slack edge of the cambered web. This indicates that the fourth boundary condition is not $Y''_0=0$. It also showed that the deflection was only a small fraction of the deflection predicted by the boundary condition $Y''_0=1/\rho_{web}$. The relationship between shear and deflection, as described by equations (24) and (27) or (39) held, indicating the cambered web was acting as a beam.

After establishing the relationship between shear and deflection, experiments were performed with deflection measurements only. A second 2^{4-1} designed experiment looked at the variables of span length, tension, camber and roller coefficient of friction. These experiments showed span length to be the critical variable.

RESULTS

The method to engineer and manufacture non-uniform web was successful at producing the desired degree of crossweb non-uniformity in machine direction length. Two methods of quantifying web bag compared favorably with each other.

Shelton's static beam model was extended to include the possibility of a non-zero curvature or moment at the downstream roller. The resulting equations are linear superpositions of Shelton's static behavior for untrammed rollers and a new set of equations that are a function of curvature at the downstream roller.

Techniques for measuring shear and deflection were discussed. Two experiments were performed. The first verified the theoretical relationship between shear and moment, as shown in figure (6).

The results of these experiments show that webs, even in short spans, deflect toward the slack edge of a cambered web. This indicates that the fourth boundary condition is not $Y''_0=0$. It also showed that the deflection was only a small fraction of the deflection predicted by the boundary condition $Y''_0=1/\rho_{web}$. The true boundary condition for Y''_0 ranges between 0 and $1/\rho_{web}$. To help determine the functional form of the fourth

boundary condition, the experimental variables were regressed against the response of ρ_L/ρ_{web} . This response is the ratio of the actual experimental determined curvature at the downstream roller, and the untensioned curvature of the cambered web. Table (1) lists the results of this experiment. The Pareto plot in figure (7) shows that span length is the only significant predictor of the actual curvature based on the untensioned curvature. The lack of correlation between ρ_L/ρ_{web} and coefficient of friction or tension, indicates that the partial traction boundary condition, as described in [3] is unlikely the correct approach. Figure (8) shows that longer spans have a downstream curvature that is only a small fraction of the untensioned curvature, whereas shorter spans retain a higher percentage. This indicates that the true fourth boundary condition may be a function of $(-L^n)$ or $(1/L^n)$.

Shelton's tapered roller theory [2] states that a moment will be produced because the low tension side of the web will ride higher on the roller, causing the roller to act like a tapered roller. Equation (40) predicts the amount of deflection based on the tilt angle ϕ . Taking the first data point in Table (1) and using the values: $Y_L=0.12\text{mm}$ (0.005 in.), $R=0.038\text{m}$ (1.5 in.), and $L=.67\text{ m}$ (24 in.), the taper angle can be calculated to be $\phi=.000062$ radians. Multiplying this angle by the web width $W=0.3\text{ m}$ (12 in.) the required radial rise is $19\text{ }\mu\text{m}$ ($741\text{ }\mu\text{ in.}$). The stack compression, based on $E_r=350\text{P}$, can be calculated to be about $0.4\text{ }\mu\text{m}$ ($17\text{ }\mu\text{ in.}$). The roller roughness is about $0.8\text{ }\mu\text{m}$ ($32\text{ }\mu\text{ in.}$). The roller air layer is about $0.4\text{ }\mu\text{m}$ ($15\text{ }\mu\text{ in.}$). These values show that the required taper is much larger than would be reasonable to expect.

$$Y_L = \frac{\phi}{6} \frac{L^2}{R_{roller}} \quad (40)$$

Figure (9) should have a L^2 type of relationship between deflection and span length. This is very limited data, but a L^2 relationship looks unlikely. If the tapered roller is the correct model, then ρ_L/ρ_{web} would be independent of span length and constant, which it clearly is not, in Figure (8).

CONCLUSIONS

1. Cambered webs do induce shear and deflection in trammed web spans. The web will deflect toward the baggy side and have shear forces consistent with the amount of deflection. The shear and deflection values are quite small in relation to factors such as tram error.
2. The actual fourth boundary condition is not $Y''_0=0$ or $Y''_0=1/\rho_{web}$, but is bracketed by these values. This boundary condition does not seem to be a function of tension or friction, but is related to span length.
3. The effect of cambered web on lateral deflection, shear and moment is to add an offset the values predicted by Shelton[1]
4. Shear, deflection and possibly moment measurements can be used to quantify the effects of cambered web.
5. Shelton's tapered roller theory is probably not an explanation of cambered web behavior.

FUTURE WORK

This paper has added theory and experimental insight into the mechanics of non-uniform web, but an exact formulation of the fourth boundary condition has not been determined. This boundary condition is required to fully understand the mechanics of non-uniform webs.

The key elements of this paper including cambered web manufacture, measurement, shear and displacement measurements along with the developed theory should be used in further investigation of the fourth boundary condition. Direct measurement of moment may be useful, but difficult to obtain. Both the shear and deflection values are very small and can only be gleaned from the noise with careful design, calibration and lots of averaging. Shear and displacement data should be compared over a larger range of conditions. Opaque web would help in the ease and accuracy of the deflection measurements. Span length seems to be the critical variable and should be investigated in the future.

ACKNOWLEDGMENTS

I would like to thank 3M company for supporting this research. I would also like to thank Dr. James N. Dobbs and Dr. Gopal Haregoppa for their assistance on this project.

REFERENCES

1. Shelton J. J., "Lateral Dynamics of a moving Web," Ph.D Thesis, Oklahoma State University, Stillwater, Oklahoma, July, 1968
2. Shelton, J.J., "Effects of Web Camber on Handling", Proceedings of the Fourth International Conference on Web Handling, Web Handling Research Center, Oklahoma State University, Stillwater, Oklahoma, June, 1997
3. Swanson, R. P., "Air Support Conveyance of Uniform and Non-Uniform Webs," Proceedings of the Second International Conference on Web Handling, Web Handling Research Center, Oklahoma State University, Stillwater, Oklahoma, June, 1993
4. Dobbs, J.N. & Kedl, D.M., "Wrinkle Dependency on Web Roller Slip", Proceedings of the Third International Conference on Web Handling, Web Handling Research Center, Oklahoma State University, Stillwater, Oklahoma, June, 1995

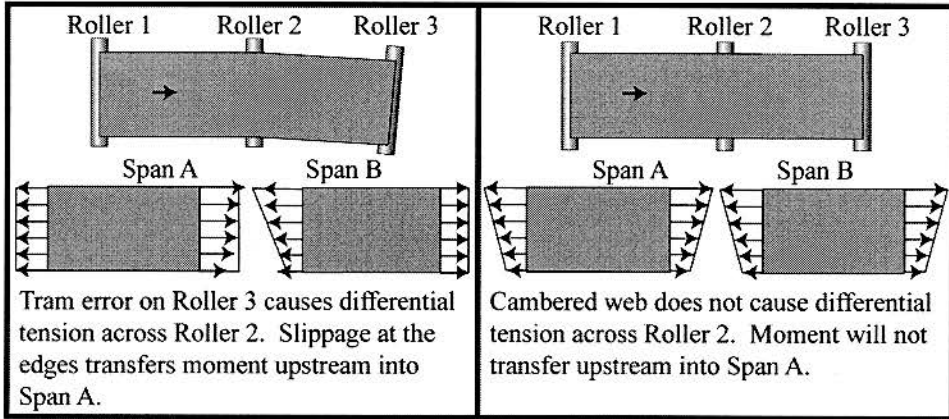

Fig. 1a Tension profile for tram error.

Fig. 1b Tension profile baggy web.

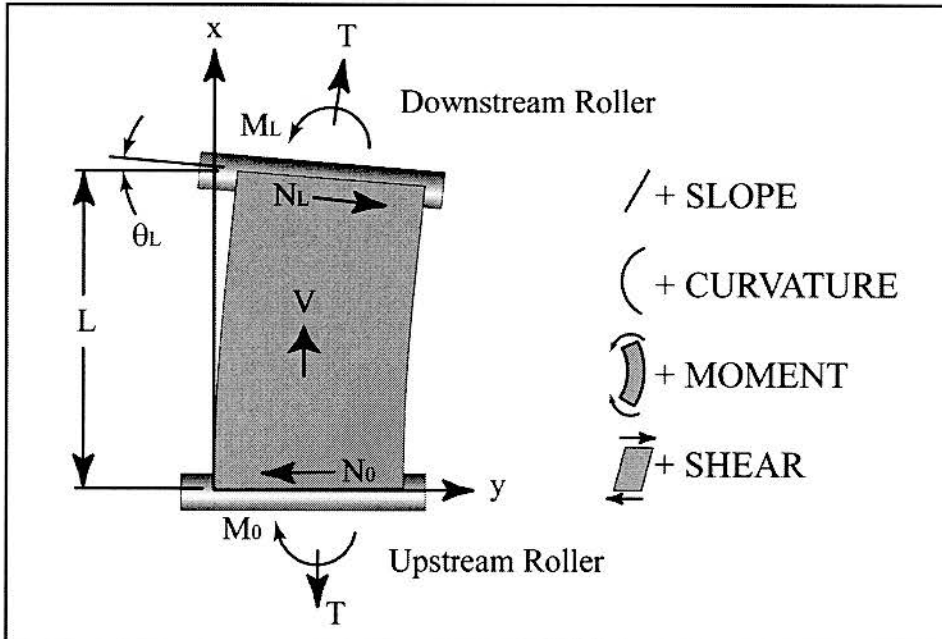

Fig. 2 Coordinate system and sign convention.

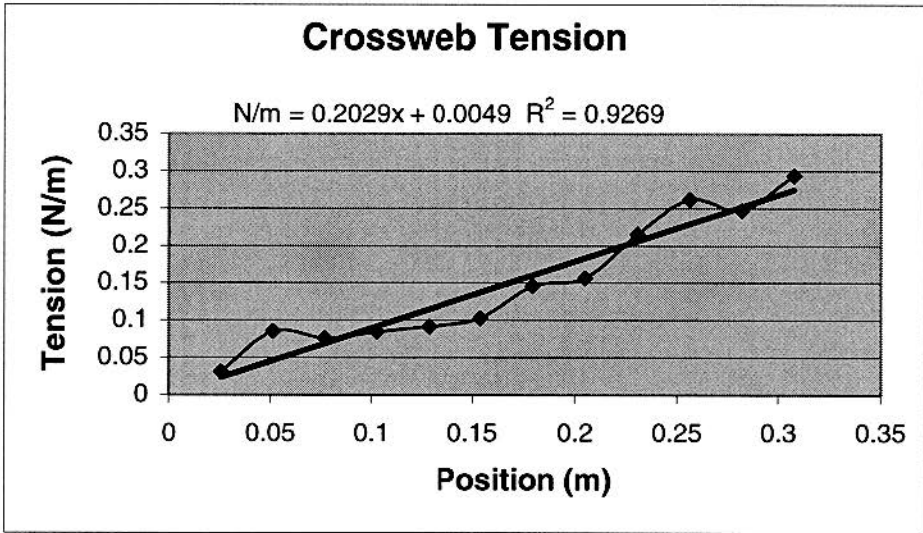

Fig. 3 Typical Crossweb Tension Plot at T_{cr}

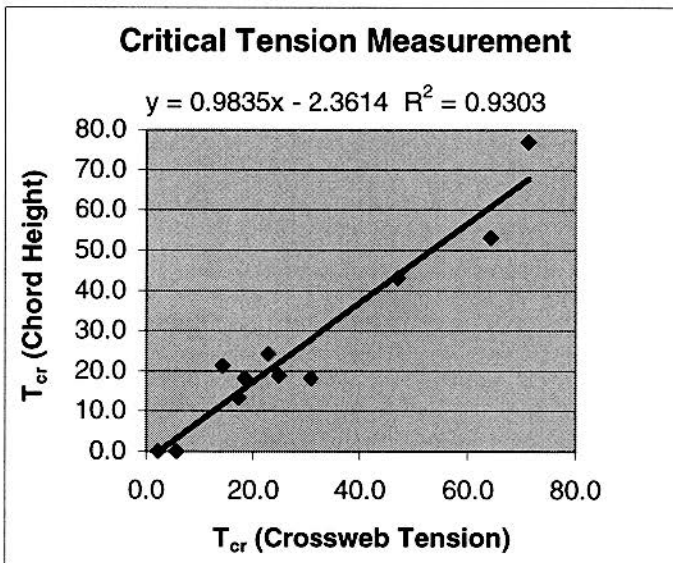

Fig. 4 Correlation between Crossweb Tension and Chord Height Measurements

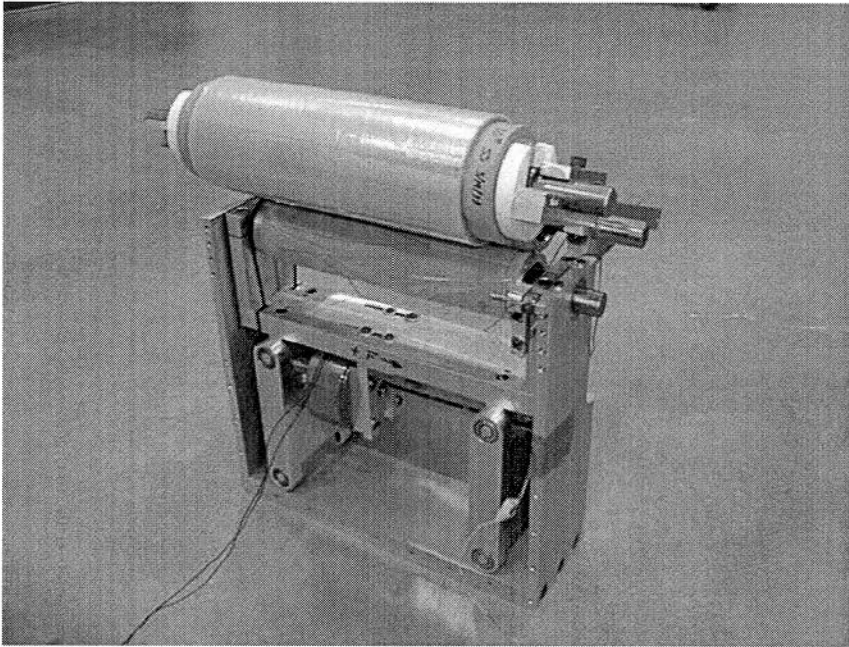

Fig. 5 Unwind stand with four bar linkage used for shear measurement.

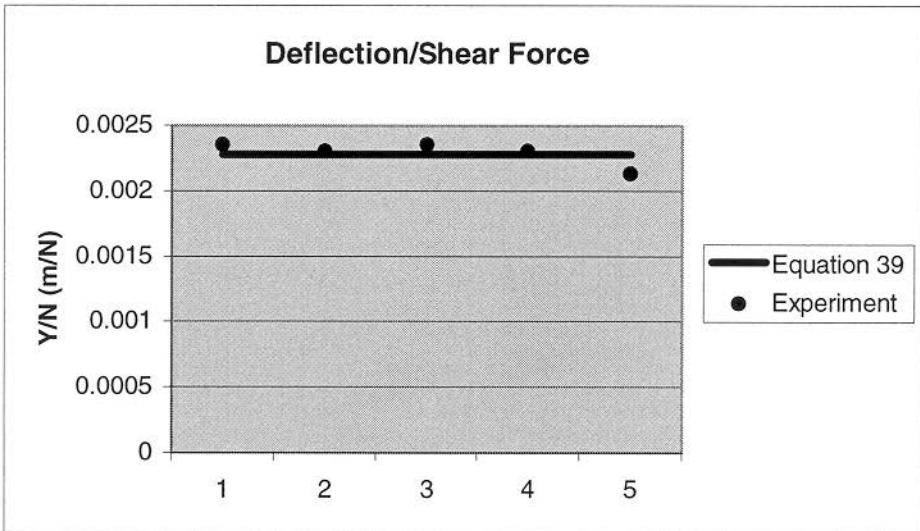

Fig. 6 Comparison of the theoretical and experimental relationship between deflection and shear force.

Span (m)	COF	Tcr (N)	T(N)	Y _L (mm)	ρ _L (m)	ρ _{web} (m)	ρ _L /ρ _w
0.67	0.20	22	22	-0.12	534	185	0.35
2.00	0.20	22	66	-0.30	1842	139	0.08
0.67	1.00	22	66	-0.16	388	115	0.30
2.00	1.00	22	22	-0.24	2319	232	0.10
0.67	0.20	66	66	-0.25	254	85	0.33
2.00	0.20	66	22	-0.75	*751	68	*0.09
0.67	1.00	66	22	-0.18	351	68	0.19
2.00	1.00	66	66	-0.29	1885	65	0.03
1.33	0.30	44	44	-0.08	3094	111	0.04

* Denotes Web Tension < Tcr (term corrected for tensioned web width)

Table 1. Displacement Experimental Results

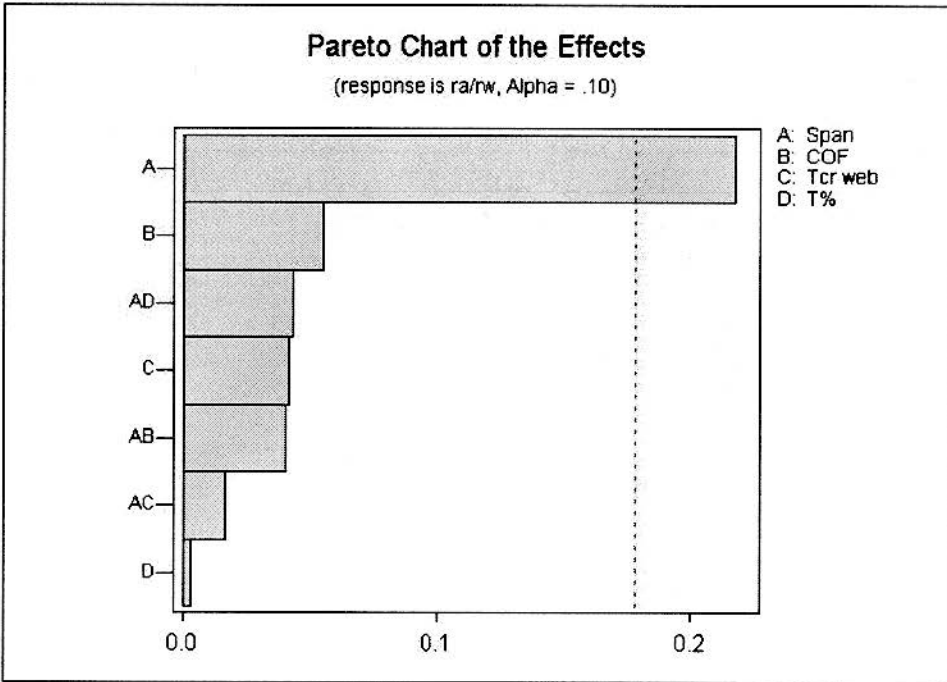

Fig. 7 Pareto Chart Showing the Statistical Significance of Span on ρ_L/ρ_{web}

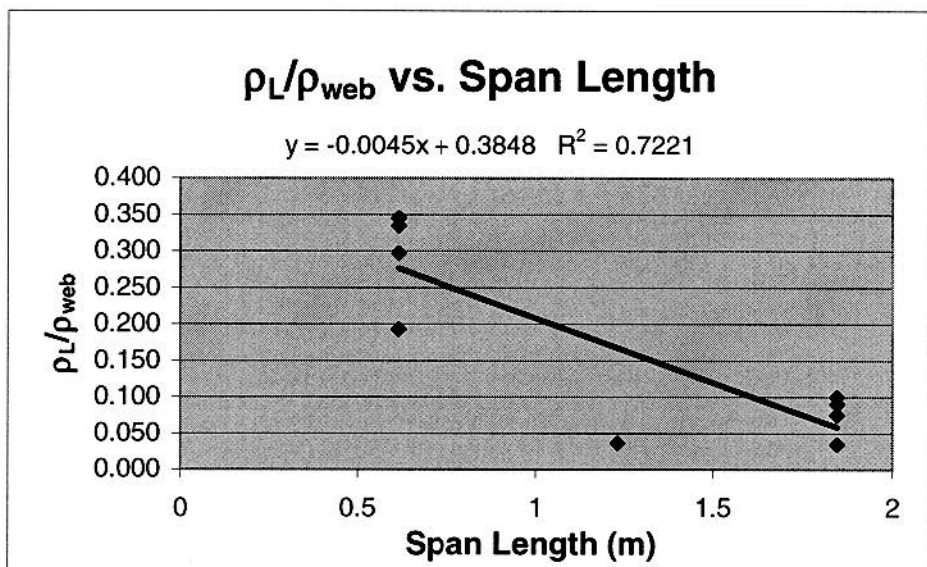

Fig. 8 Plot of ρ_L/ρ_{web} vs. Span Length

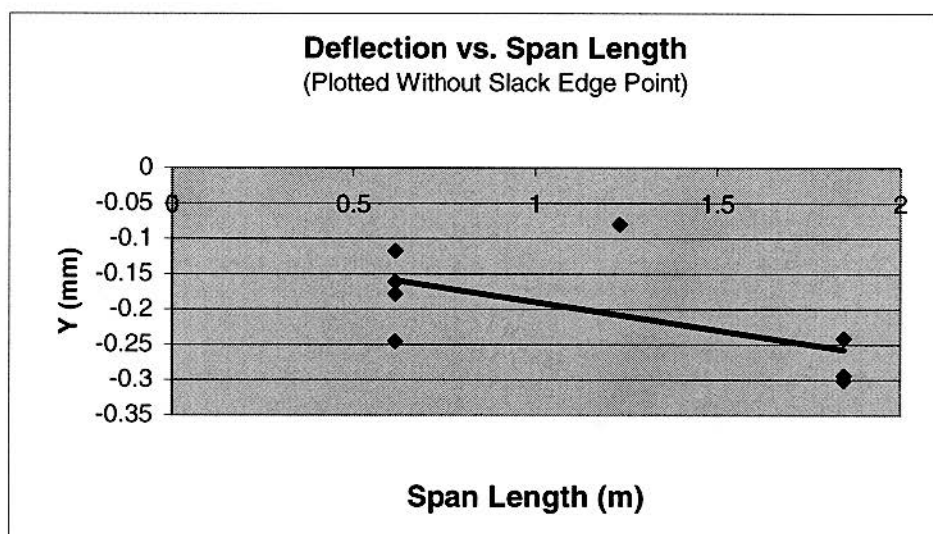

Fig. 9 Plot of Y_L vs. Span Length

R. P. Swanson

Mechanics of Non-Uniform Webs

6/9/99

Session 4

9:00 - 9:25 a.m.

Question - Mike Holmberg, Rexam

Ron, I noticed there was second order interaction in your design of the experiment and they had no significance. I was wondering, would you expect any significance from higher order interactions if you had done like a full factorial?

Answer - R. P. Swanson, 3M Company

You know the one interaction I was surprised I didn't find was tension and coefficient in friction would combine to form what we call traction. I'm surprised that that didn't come up significant.

Question - Mike Holmberg, Rexam

Those may come up on a full factorial because you may have lost it with some of the interactions with the fractional factorial design. Did you think about doing a full factorial design?

Answer - R. P. Swanson, 3M Company

This is resolution IV Design so all we lost is the third order interactions which are rarely significant.

Comment - Mike Holmberg, Rexam

Okay.

Question - David Pfeiffer, JDP Innovations Inc.

I am kind of surprised too that the coefficient of friction did not enter into your results. Would you make the conclusion then that possibly it takes very little coefficient of friction to establish traction? And that you always had traction in all experiments all the way across the roll in the whole experiment?

Answer - R. P. Swanson, 3M Company

It could be. My traction varied from a Teflon coated roll to a silicon rubber roll, as big as it think I could make, but, even under those conditions, I am sure that we still had normal entry.

Question - David Pfeiffer, JDP Innovations Inc.

Okay. So if you were fully air floated out over the roll I know it would be the same as a sliding turning bar or other stationary bar kind of turning an everything would break down and you'd get a jump in your results. But you didn't see that so traction was ever lost?

Answer- R. P. Swanson, 3M Company

It very well could be.

Question - Wolferrmann, Technical University of Munich

How did you measure the cross web tension?

Answer - R. P. Swanson

I had a device that measured the tension every inch across the web. I suppose you know want to know the device. You know it's not a fancy device and we've talked about several ways of doing it at other IWEB conference. I'm not going to discuss the actual device. There's numerous ways of doing it.